

PUBLIC

高圧直流送電（HVDC）について

～カーボンニュートラルの実現に向けて～

NEDO 特別講座 産学合同セミナー

2023-12-21

© 2023 Hitachi Energy. All rights reserved.

HVDCとは？

- ✓ 長距離送電、ケーブル送電
- ✓ 低損失送電
- ✓ 高品質・高信頼の系統連系

を実現するソリューションです。

→ **Energy Transition、Carbon Neutrality 実現のための
キーテクノロジーの一つ**

2

Public
© 2023 Hitachi Energy. All rights reserved.

HVDC の例 ± 525 kV / 1,400 MW 双極、長距離海底ケーブル送電

HITACHI
Inspire the Next

ノルウェー (約 600 km 先)

直流

+ 525 kV

- 525 kV

交流

ドイツ

Tønstad (Ertsmyra)

約 600 km

Wilster

※ 電力の流れは双方向です。

Public
© 2023 Hitachi Energy. All rights reserved.

HVDC の例 ± 320 kV / 1,200 MW 対象単極、洋上風力連系

交直変換

イギリス

Dogger Bank A

約 130 km

Hitachi

aibel

Public
© 2023 Hitachi Energy. All rights reserved.

Hitachi Energy

HVDC 交直変換バルブの例

HITACHI
Inspire the Next



5

HITACHI
Inspire the Next

Table of contents

1. 世界の HVDC
2. HVDC とは
3. HVDC の系統サポート
4. システム解析
5. プロジェクト事例
6. 日立のHVDC事業

6

Public
© 2023 Hitachi Energy. All rights reserved.

 **Hitachi Energy**

HITACHI
Inspire the Next

世界のHVDC

Hitachi Energy

7 Public
© 2023 Hitachi Energy. All rights reserved.

欧州で進む連系強化

HITACHI
Inspire the Next

欧州の“10 Year Network Development Plan” (TYNDP 2020)

欧州では、連系強化が社会・経済的に有効であると評価されており、今後もさらに連系強化を進める計画。

93 GW
cross-border capacity
increases needed by 2040
(TYNDP 2020)



20年間で93 GW

64 GW
cross-border capacity
increases needed by 2030
(TYNDP 2022)

8年間で64 GW

(entso-e* 2020年版10年計画)

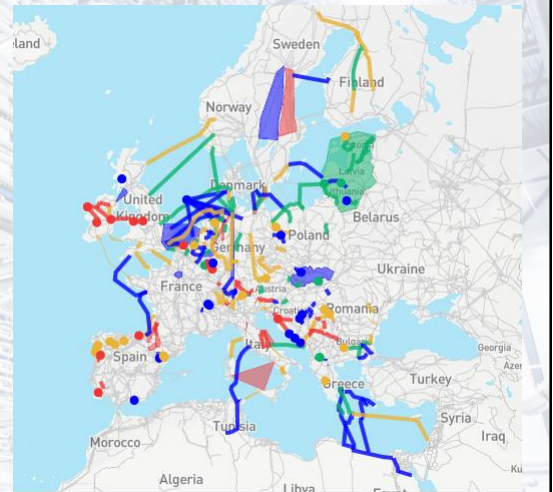

出典: ENTSO-E <http://www.entsoe.eu/>
Map of TYNDP 2020 transmission projects. Areas indicate projects for which the route is not yet known, (Green: project under construction, Yellow: project in permitting, Red: Project planned but not yet in permitting, Blue: project under consideration)

* entso-e: The European association for the cooperation of Transmission System Operators (TSOs) for electricity (欧州送電システム事業者ネットワーク協会), UCTE+英国+北欧+バルト三国 (entso-eエリア)の系統規模: 日本の約3.5倍
UCTE: The Union for the Co-ordination of Transmission of Electricity (欧州大陸主要部の同期系統)

8 Public
© 2023 Hitachi Energy. All rights reserved.

Hitachi Energy

連系強化の動機、効果

“ We build interconnections because it's **social welfare**, beneficial for both society and economy. It is not Statnett's economical benefit because the congestion revenue from interconnections are passed on to Statnett's customers through reductions in tariffs. ”
Statnett, Norway

entso-e TYNDP 2022:

64 GW の連系増強 (2022 - 2030) により

【2030年断面】

- ✓ 17 TWh/年 再エネ抑制回避 (35 ⇒ 18 TWh/年)
- ✓ 9 TWh/年 天然ガス発電削減 (393 ⇒ 384 TWh/年)
- ✓ 14 Mton/年 CO₂ 歳出削減 (323 ⇒ 309 Mton/年)
- ✓ 50億 €/年 発電コスト削減 (1,040 ⇒ 990 億€/年)

【2040年断面】

- ✓ 42 TWh/年 再エネ抑制回避 (78 ⇒ 36 TWh/年)
- ✓ 75 TWh/年 天然ガス発電削減 (366 ⇒ 291 TWh/年)
- ✓ 31 Mton/年 CO₂ 歳出削減 (175 ⇒ 145 Mton/年)
- ✓ 90億 €/年 発電コスト削減 (1,320 ⇒ 1,230 億€/年)

の効果が見込まれる。

※ Statnett では、連系線からの収入が消費者に還元されている。

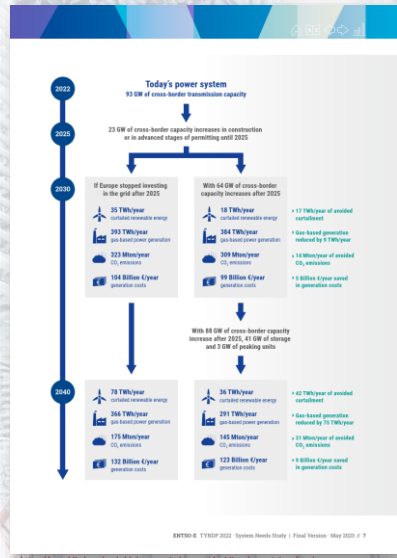

連系増強が加速

【entso-e 連系強化検討の目安】

- 市場価格差の極小化 >€2 / MWh (年平均)
- 供給信頼性の向上 連系容量 < ピーク需要の30%
- 再エネの共有 連系容量 < 再エネ導入量の30%

連系強化を検討すべき目安とされている。

Report of the Commission Expert Group on electricity interconnection targets, Nov 2017

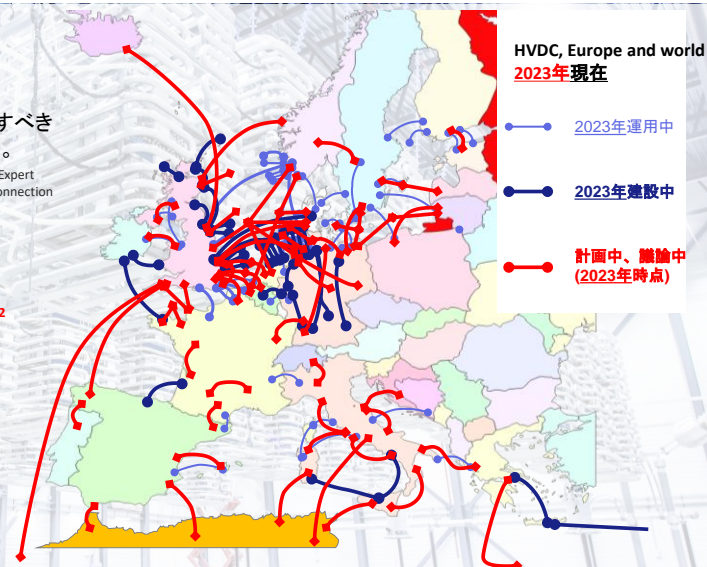
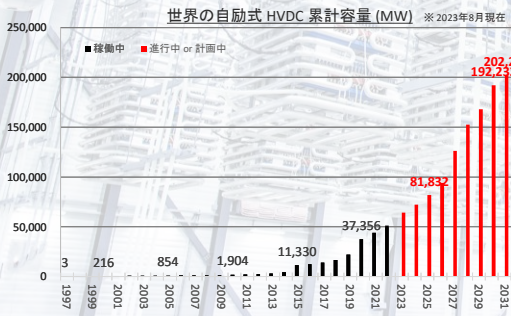

なぜ脱炭素の主力として「風力+連系強化」が選択されているか



IEA: Net Zero by 2050, a roadmap for global energy sector
<https://www.iea.org/reports/net-zero-by-2050>
https://www.iea.org/reports/net-zero-by-2050-abstract-for-the-global-energy-sector_CO28.pdf

IPCC: Climate Change 2022: Mitigation of Climate Change
<https://www.ipcc.ch/report/ccr/wg3/>

Hitachi Social Innovation Forum 2023
 (Gerhard Serge, CTO of Hitachi Energy)

- CCUS: Around 55% of the cumulative emissions reductions that come from CCUS in the NZE are from technologies that are at the demonstration or prototype stage today. While CO₂ capture has been in use for decades in certain industrial and fuel transformation processes, such as ammonia production and natural gas processing, it is still being demonstrated at a large scale in many of the other possible applications.
- Bioenergy: Around 45% of the cumulative emissions reductions in the NZE related to sustainable bioenergy come from technologies that are at the demonstration or prototype stage today, mainly for the production of biofuels.

Figure 2.32 – Cumulative CO₂ emissions reductions for selected technologies by maturity category in the NZE

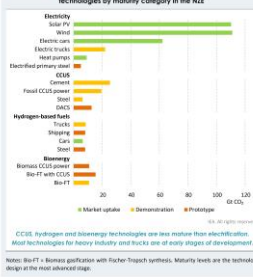

Summary for Policy-makers

Many options available now in all sectors are estimated to offer substantial potential to reduce net emissions by 2050. Relative potentials and costs will vary across countries and in the longer term compared to 2020.

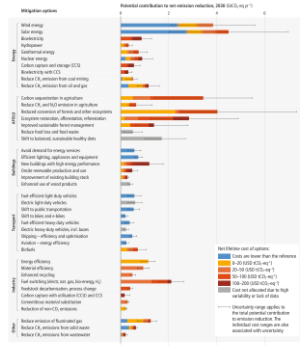
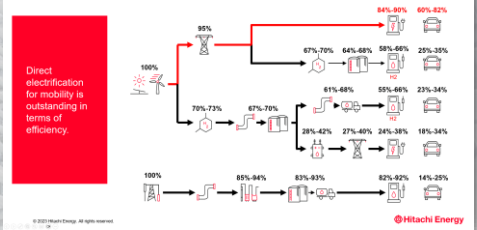

Figure 2M2 | Overview of mitigation options and their estimated ranges of costs and potentials in 2050

Electrifying transport – highest efficiency and lowest emissions



電力部門は2035年に脱炭素化をほぼ達成 ~G7 コミットメント~



of avoiding undue dependencies in global clean energy supply chains including various manufacturing processes as well as key raw materials production, which can bring diversification and potential challenge for the energy transition. To achieve the interim goal of net zero emissions by 2050 at the latest, we emphasize the importance of scaling up investments into the manufacturing and installation of clean energy technologies such as electrolyzers, heat pumps and batteries, and diversifying clean energy supply chains to as electrolyzers, heat pumps and batteries, and diversifying clean energy supply chains to a new end ensures they are resilient, affordable, and sustainable, while being consistent with internationally recognized labor standards and respecting human rights. We recognize these efforts offer numerous opportunities such as investments and job creation, and environmental opportunities to reduce GHG emissions through industrial activities in countries whose energy mix is low-carbon intensive. Recognizing the significant increase of the end of life products relating to clean energy technologies, we stress the important role of product design with a view to enhancing the circularity of value chains of clean energy technologies as a contribution to security of supply.

66. Power systems: Recognizing the need to urgently curtail greenhouse gas emissions in this critical decade, we recall the 2022 G7 Leader's Communiqué and reaffirm our commitment to achieving a fully or predominantly decarbonized power sector by 2035, and prioritizing concrete and timely steps towards the goal of accelerating the phase-out of domestic unabated coal power generation in a manner consistent with keeping a limit of 1.5°C temperature rise within reach and urge others to join us. To implement this G7, COP28 や 札幌で開催された 気候・エネルギー・環境大臣 会合などで繰り返し述べられている

66. Power systems: Recognizing the need to urgently curtail greenhouse gas emissions in this critical decade, we recall the 2022 G7 Leader's Communiqué and reaffirm our **Commitment to achieving a fully or predominantly decarbonized power sector by 2035,** and prioritizing concrete and timely steps towards the goal of accelerating the phase-out of domestic unabated coal power generation in a manner consistent with keeping a limit of 1.5°C temperature rise within reach and urge others to join us. To implement this G7, COP28 や 札幌で開催された 気候・エネルギー・環境大臣 会合などで繰り返し述べられている

We recognize the need to end the construction of new unabated coal-fired power generation as identified in the IEA's Coal in Net Zero Transitions report in 2022 as one of the primary actions to be taken in line with the IEA net zero by 2050 scenario. We call on and will work with other countries to end new unabated coal-fired power generation projects globally as soon as possible to accelerate the clean energy transition in a just manner. In doing so, we reaffirm the importance of national energy security, affordability and resilience and underscore the need to tackle energy poverty and the importance of providing support for affected workers, regions and communities. We will invite IEA with support from relevant organizations, such as the ILO to report on the various actions to accelerate the phase-out of domestic unabated coal power in a manner consistent with a just transition.

G7 Climate, Energy and Environment Ministers' Communiqué (Page25)



海外の先行事例（自国へ風力投資を呼び込むため系統整備を先行）



【3か国の共通点】

- 連系線、アクセス線を含む**グリッドの整備を先行**し、洋上風力への**投資を促進**（条件が不利だと自国に投資が来ない）
- シンプル・標準的な HVDC により、短期間で建設
- 最新動向：自励式 HVDC 2,000 ~ 3,000 MW クラスプロジェクトの増加、Framework Agreement による生産枠確保の動きが強まる

ドイツ

【日本との類似点】

- 北部に大量の風力ポテンシャル、南部（遠距離）に大需要地

【示唆】

- セントラル方式で風力の建設エリアとHVDC送電線を建設し、洋上風力への投資を促進（当初はHVDCはアクセス線扱いだった）
- 北部⇄南部を結ぶ、大容量・長距離HVDCを5本建設 → 国内マスタープランに類似
- 2030年に30GW、2035年に40GWの洋上風力ターゲット

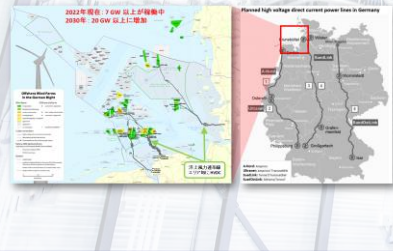

Public © 2023 Hitachi Energy. All rights reserved.

デンマーク

【日本との類似点】

- ほぼ北海道と同サイズ
- 最大需要を超える風力を導入
- 周辺系統と複数の連系を持つことにより、供給信頼性を向上（リスクを低減）
- 再生可能エネルギー比率が高く、供給信頼性も高いため、多くのRE100企業が投資（Apple, Google, META等がデータセンター建設）
- 再エネ率（年間）が60%超（2018年）

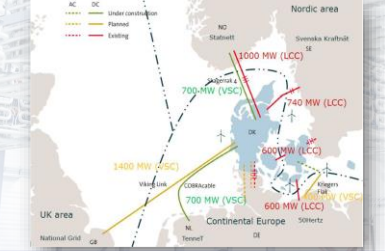

英国

【日本との類似点】

- 周囲に海に囲まれた島国
- OFTO方式で、洋上風力の投資を促進
- 周辺各国と複数の連系、国内も複数の南北連系等を持つことにより、供給信頼性を向上（リスクを低減）
- 風力の発電量が少ないときは、周辺国から輸入
- 2030年50GWの洋上風力を稼働

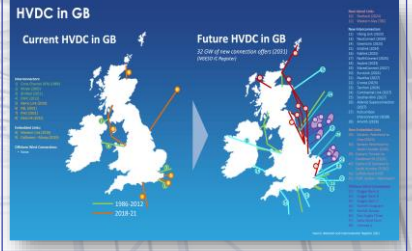

ドイツの例



洋上風力連系線

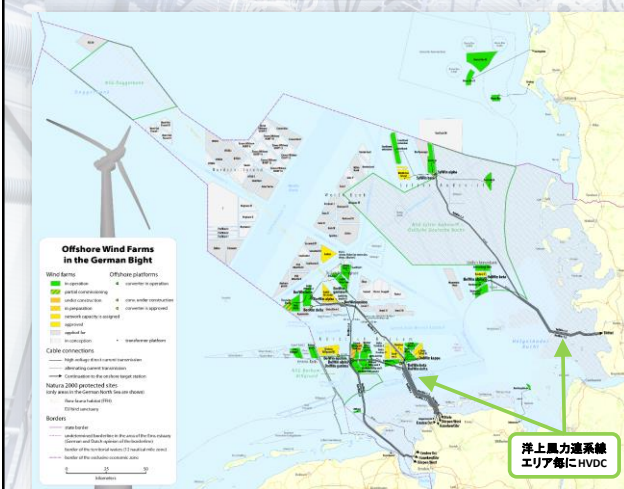

https://en.wikipedia.org/wiki/List_of_offshore_wind_farms_in_Germany

系統連系線



<https://www.cleanenergywire.org/factsheets/set-and-challenges-germanys-power-grid>



Energy Transition が加速

HITACHI
Inspire the Next

TenneT が 28 GW (14 x 2 GW) の洋上風力連系 HVDC を建設 (独、蘭、2028 – 2031 に順次運開)

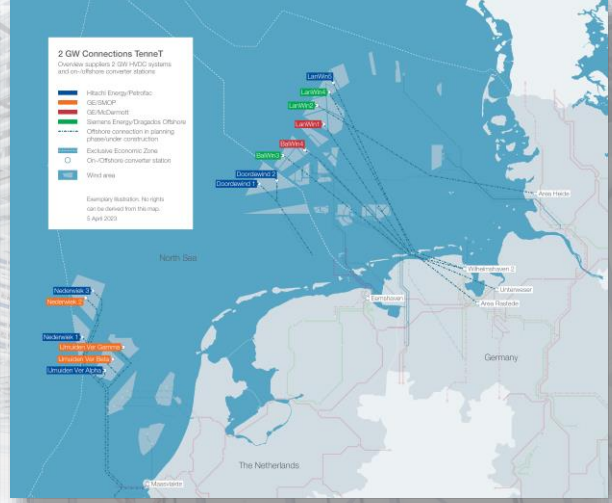
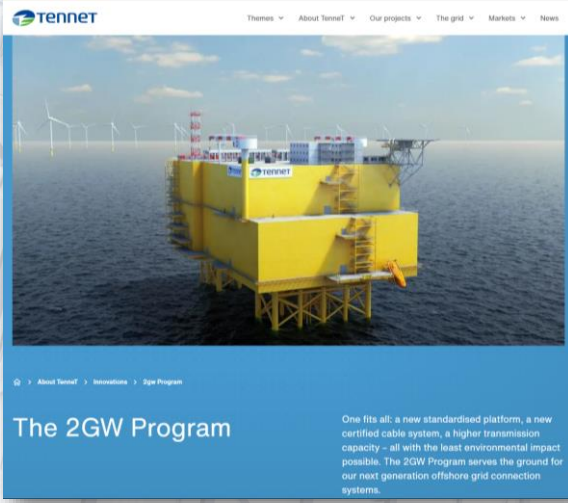

<https://www.tennet.eu/news/around-eu-90-billion-europes-largest-ever-contracting-pack-age-security-supply-energy>



15 Public © 2023 Hitachi Energy. All rights reserved.

ドイツ国内システムのさらなる系統増強 (HVDC Korridore)

HITACHI
Inspire the Next

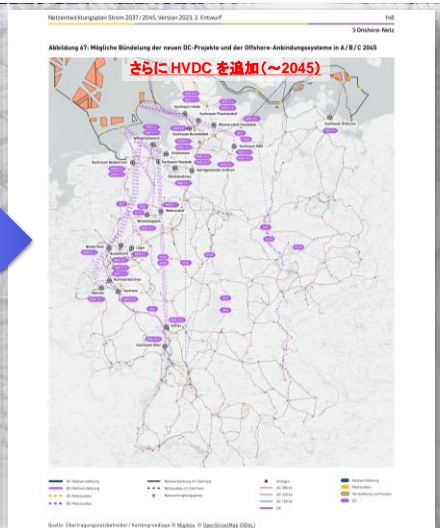

<https://www.transnetbw.de/de/newsroom/presseinformationen/fuer-eine-sichere-energiezukunft-sihertz-tennet-und-transnetbw-realisieren-gemeinsam-neue-gleichstrom-verbindungen>

https://www.netzentwicklungsplan.de/sites/default/files/2023-12/NEP%20kompakt_2037_2045_V2023_2E.pdf



16 Public © 2023 Hitachi Energy. All rights reserved.

デンマークの例

- 人口 (5.6 million)、系統規模 (最大需要 約 6 GW) が北海道に類似している
- 風力の設備容量はすでにデンマークのピーク需要を上回っており、さらに風力を増やす計画 (ピーク需要の 3 倍を目指す)
- 風が強い日には、国内消費電力が100%風力になる日もある
- 直流連系線は以下
 - Kontek 1 (DK-DE) 600 MW
 - Storebælt 1 (DK-DK) 600 MW
 - Konti-Skan 1 (DK-S) 380 MW
 - Konti-Skan 2 (DK-S) 360 MW
 - Skagerrak 1 (DK-N) 275 MW
 - Skagerrak 2 (DK-N) 275 MW
 - Skagerrak 3 (DK-N) 500 MW
 - Skagerrak 4 (DK-N) 715 MW
 - Cobra 1 (DK-NL) 700 MW
 - Vikings Link (DK-UK) 1,400 MW
 - Kriegers Flak※ (DK-DE) 400 MW ※ドイツ側にBtB
- 今後洋上風力の HVDC 連系も増える
- Apple、Google、Facebook がデータセンターを設置 (Apple のデータセンターは、Skagerrak 変換所の隣に建設)

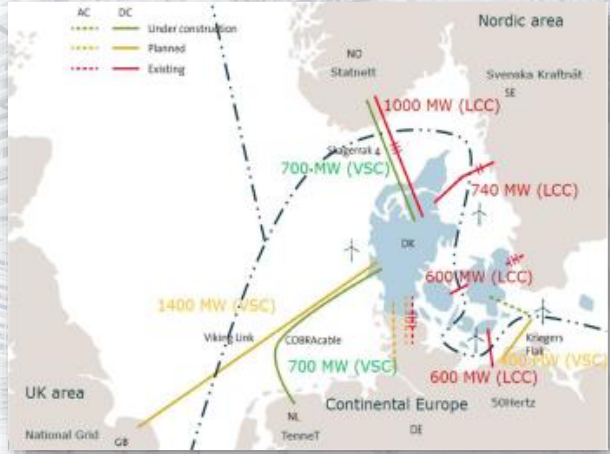

Source: Energinet.dk

デンマークは再エネ比率で世界トップクラス

FLEXIBILITY FROM THE ENERGY MIX
A RANDOM WEEK – NOVEMBER 17-23, 2020

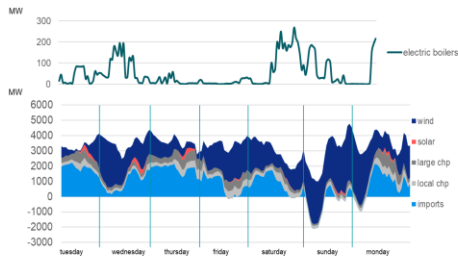

Source: Energinet.dk

Figure 2. Annual VRE share and corresponding system integration phase in selected countries/regions, 2018

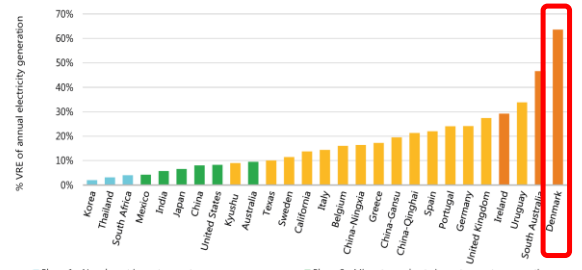

Note: China = the People's Republic of China.
Source: IEA (forthcoming), Renewables 2019: Analysis and Forecasts to 2024.

Apple Viborg Data Center (デンマーク)

Apple が Skagerrak HVDC station の隣に大規模データセンターを建設 (消費電力: 約 200 MW !!)

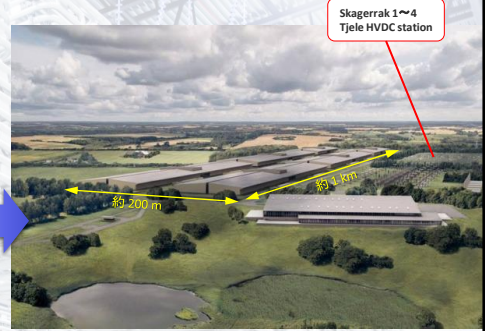

最終的に 6 棟となる

Google、META (Facebook) もデンマークにデータセンター建設

デンマークの Energy Island

World's First Energy Islands Green power plants at sea

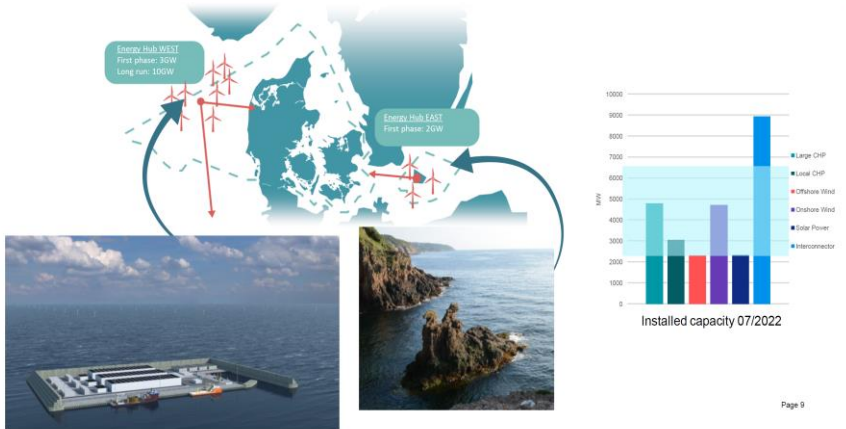

Source: Energinet.dk

英国の例

- 系統規模(最大需要約 63 GW)は日本の約 1/3、海で囲まれているところは日本と類似
- 洋上風力の導入目標: **50 GW in operation by 2030**
- 多数の直流連系線により供給セキュリティーを確保
16 GW (2027) ⇒ 32 GW (2031)

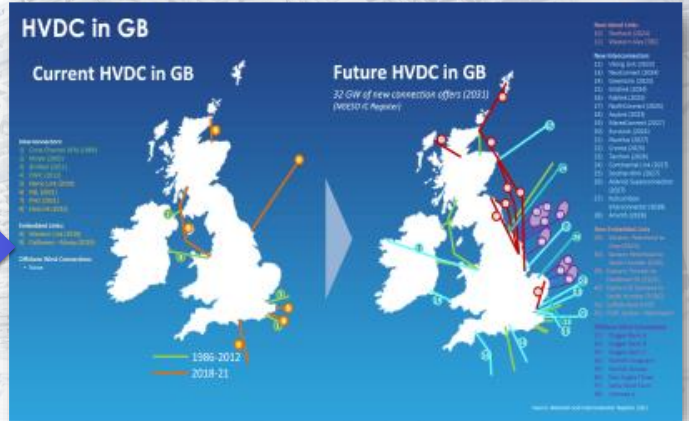
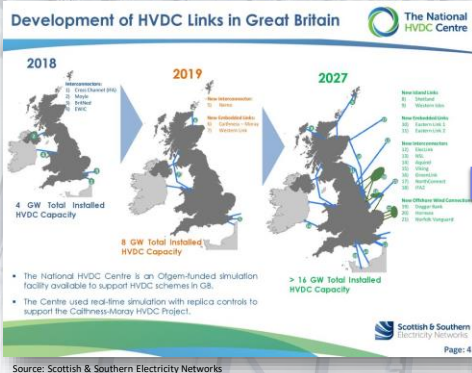

Energy Transition が加速

“Together, the nine countries set offshore wind targets of about **120 GW by 2030** and **300 GW by 2050** in the North Seas. Today the North Seas have a combined capacity of less than 30 GW.”

Press releases
24 April 2023

EU leaders meet in Ostend to agree rapid build-out of offshore wind in the North Seas

Nine Heads of State & Government and the President of the EU Commission meet today in Ostend to agree new commitments on the build-out of offshore wind in the North Seas. This is a follow-up to last year's Summit of Belgium, Denmark, Germany and the Netherlands in Esbjerg. Those four are joined today by France, Ireland, Luxembourg, Norway and the UK. In an historic Declaration, more than 100 companies, representing the whole value chain of offshore wind and renewable hydrogen in Europe, outline what the nine Governments need to do now to deliver their offshore wind ambitions.

The Heads of State & Government of Belgium, Denmark, Germany, France, Ireland, Luxembourg, the Netherlands, Norway and the UK meet today in Ostend to agree new commitments on offshore wind in the North Seas. They are joined by the President of the European Commission, their respective national Energy Ministers and the EU Energy Commissioner – and by over 100 CEOs from across the offshore wind value chain. It's by far the biggest ever political Summit on energy in the North Seas. The aim: make the North Seas a renewable powerhouse for Europe.

To this end, the countries will sign two political declarations: the official **Osind Declaration** and a more detailed **Energy Minister Declaration** which aims to deliver cross-border projects and anchor the renewable offshore industry in Europe. The Energy Minister Declaration contains national expansion targets for wind energy and interconnector capacity. Together, the nine countries set offshore wind targets of about 120 GW by 2030 and 300 GW by 2050 in the North Seas. Today the North Seas have a combined capacity of less than 30 GW.



HITACHI
Inspire the Next

HVDCとは

23 Public © 2023 Hitachi Energy. All rights reserved.

 Hitachi Energy

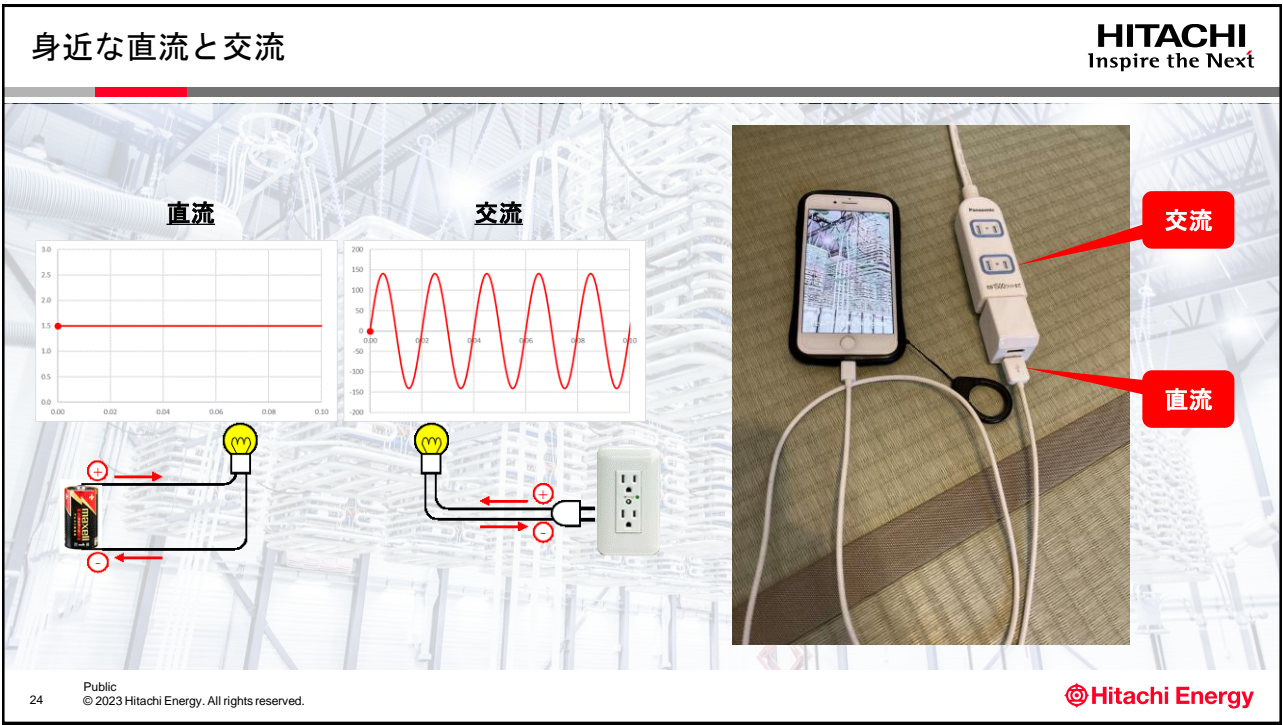

HITACHI
Inspire the Next

身近な直流と交流

直流

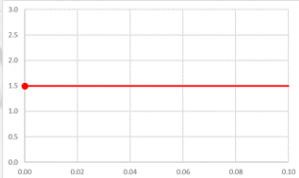
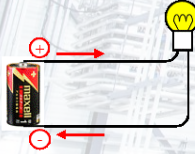
交流



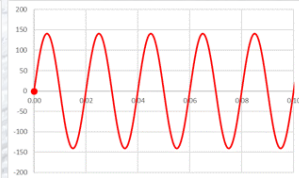
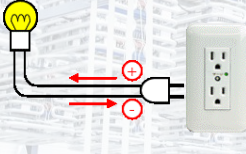



交流

直流

24 Public © 2023 Hitachi Energy. All rights reserved.

 Hitachi Energy

直流 vs 交流

HITACHI
Inspire the Next

- ◆ トーマス・エジソンが、1882年ニューヨークで直流 110V の送電を開始
電線が長くなると高負荷時電圧降下が大きくなり問題...
 - ◆ 1886年にジョージ・ウェスティングハウスが、水車発電機の 500V 交流を 3,000V に昇圧し送電(受電端では変圧器で 100V に)
 - ◆ 1887年エジソンの従業員テスラが、交流発電機、変圧器、交流電動機などを発明。直流の問題解決を提案するも断られ独立。
 - ◆ その後どろどろの戦い...
 - ◆ 1893年コロンブス博覧会でテスラとウェスティングハウスによる洗練された交流機器の展示。それに続きナイアガラ水力発電所が、テスラの交流方式を採用し 2,200V で送電。以後、急速に交流方式が広まる。
- ※ 実はマンハッタンでは、2005年まで直流配電が存在していました。

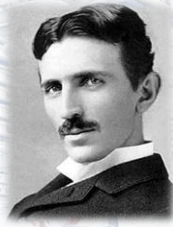

25 Public
© 2023 Hitachi Energy. All rights reserved.

Hitachi Energy

1800年代末：長距離送電に適した交流（テスラ陣営）が勝利

HITACHI
Inspire the Next

- ◆ 直流は容易に電圧を変えられない
 - 需要端(電灯)が 110V ⇒ 110V で送・配電
⇒ 1マイルほどで電圧降下大。
 - 電圧降下が大きいため、需要地近くに発電所を分散して設置。コスト大。
 - 電灯用と動力用(より高電圧)を、別ラインで配電。これもコスト大。
- ◆ 交流は容易に電圧を昇圧可
 - 抵抗損失は電流の二乗に比例。高電圧化で電流を小さくし、損失と電圧降下を小さくできる
 - これにより、**より長距離送電が可能に**

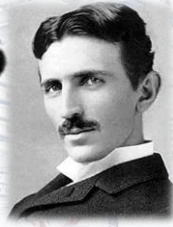

直流は適した用途に適した電圧で(限定的に)使用 ... 電車、パソコン、EV、蓄電池 etc

26 Public
© 2023 Hitachi Energy. All rights reserved.

Hitachi Energy

なぜ今「長距離」に直流なのか？

HITACHI
Inspire the Next

1800年代末、交流(テスラ)は、“長距離”送電により直流(エジソン)に勝利した。
なぜ今“長距離”で直流になるのか？

【今日の課題】

- 「長距離」がより長くなった
- ケーブル送電の増加
(交流ケーブル送電は実質 50 ~ 100 km が限界*)
- 架空送電線の長い建設期間
(再エネ等の事業計画に難)

HVDC の特徴

- 長距離の低損失送電
- 長距離ケーブル送電
- 既存交流系統のサポート (安定化)

⇒ 大規模な再エネの導入には長距離送電(再エネ連系および地域間連系)が不可欠であり、Energy Transition・CNの早期実現に、HVDCが貢献する。

* 100 km を超える交流ケーブル送電がいくつかある。

27 Public
© 2023 Hitachi Energy. All rights reserved.

Hitachi Energy

(参考) 架空線送電 と ケーブル送電

HITACHI
Inspire the Next

架空送電線

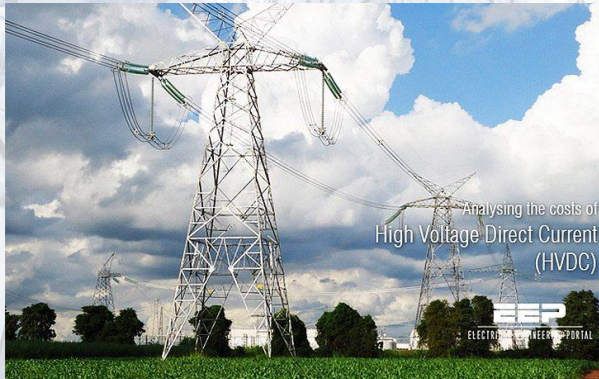

<https://electrical-engineering-portal.com/analysing-the-costs-of-high-voltage-direct-current-hvdc-transmission>

電力ケーブル

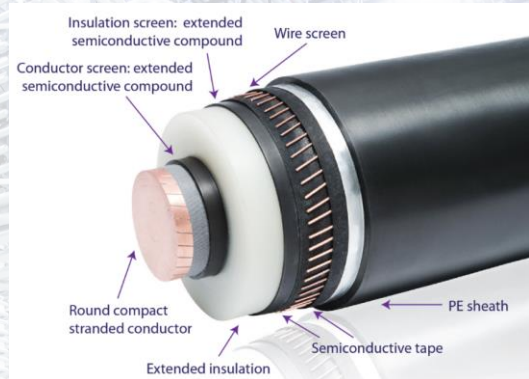

<https://www.tdworld.com/intelligent-undergrounding/article/20972392/iowa-developer-to-build-3-billion-renewable-energy-powerline>



長距離ケーブル送電は、交流では難しく、直流が最適

28 Public
© 2023 Hitachi Energy https://www.kitaniti-td.co.jp/products/cable_wire/power/acsr/index.html

Hitachi Energy

(参考) ケーブル敷設の例

HITACHI
Inspire the Next

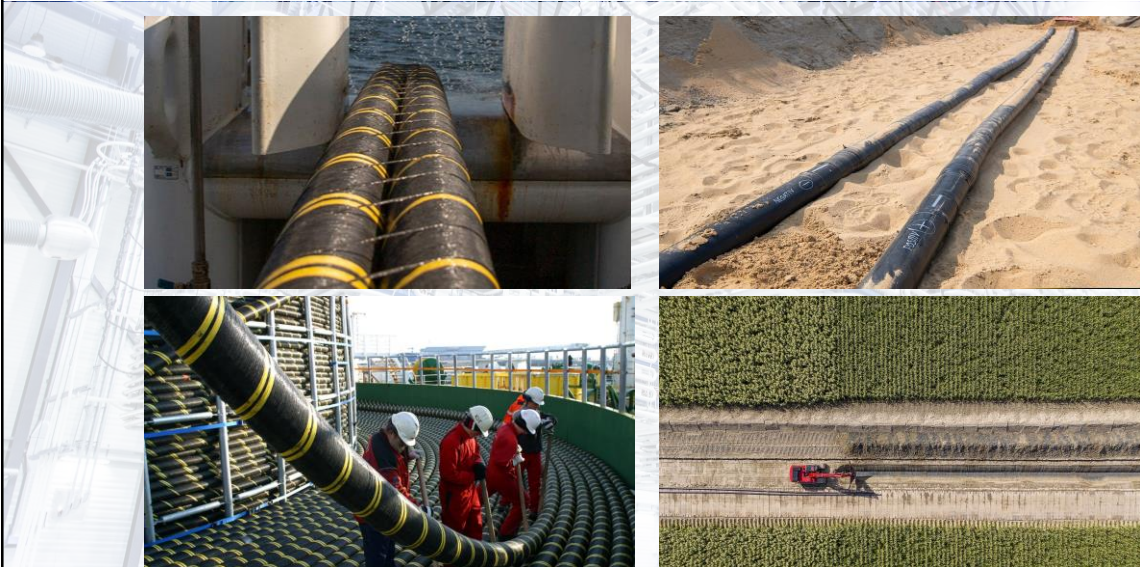

29 Public
© 2023 Hitachi Energy. All rights reserved.

<https://www.nkt.com/products-solutions/high-voltage-cable-solutions/installation/offshore-installation>
<https://www.offshorewind.biz/2017/03/01/abb-and-nkt-complete-high-voltage-cable-business-deal/>
<https://www.tennet.eu/our-grid/international-connections/nordlink/>

Hitachi Energy

送電距離 と 交流 vs 直流

HITACHI
Inspire the Next

長距離架空線送電 建設コスト

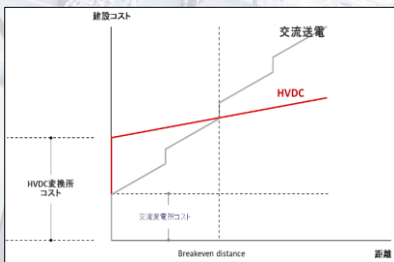

長距離架空線送電 電力損失

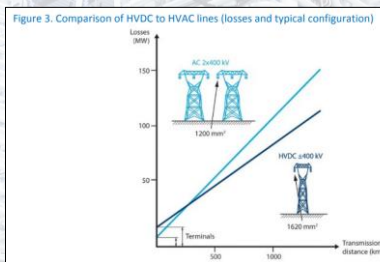

U.S. Energy Information Administration, "Assessing HVDC transmission for Impacts of non-dispatchable generation"

ケーブル送電

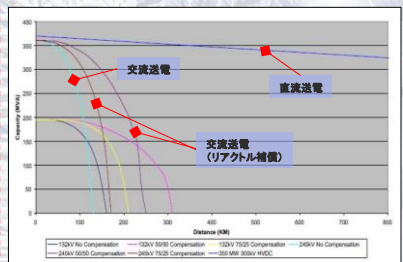

Crown Estate, "East Coast Transmission Network Technical Feasibility Study"

30 Public
© 2023 Hitachi Energy. All rights reserved.

Hitachi Energy

HVDCのアプリケーション

HITACHI
Inspire the Next



遠隔電源の送電
Connecting remote generation



異なる系統の連系
Interconnecting grids



洋上風力連系
Offshore wind connections



同期交流系統内の直流送電
DC links in AC grids



洋上への送電
Power from shore



都市部への電源供給
City center infeed



遠隔負荷への送電
Connecting remote loads



交流と直流の変換 他励式と自励式

HITACHI
Inspire the Next

他励式と自励式

他励式変換器

交流の電源電圧を切り替えて直流電圧を作る
(スイッチングに交流電源が必要)

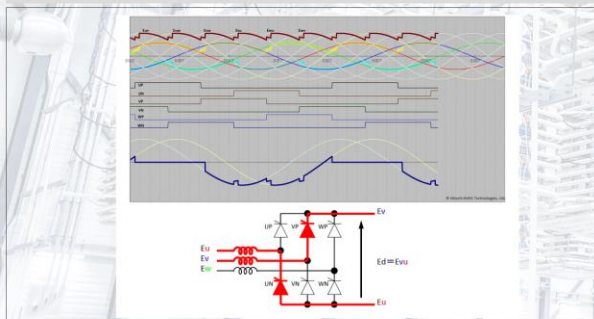

自励式変換器 (マルチレベル)

直流電源を持っており、直流の電源電圧を高速にスイッチングすることにより、交流側の出力電圧振幅、位相を制御する

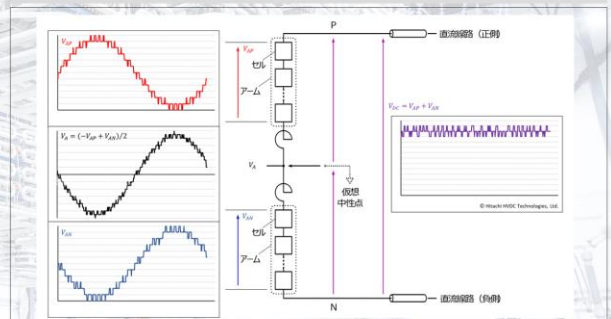

他励式HVDC

他励式HVDCの基本原則(例)

両端で交流電源を整流し直流電圧を作る。両端の直流電圧の差により電流を流し、電力を送る。

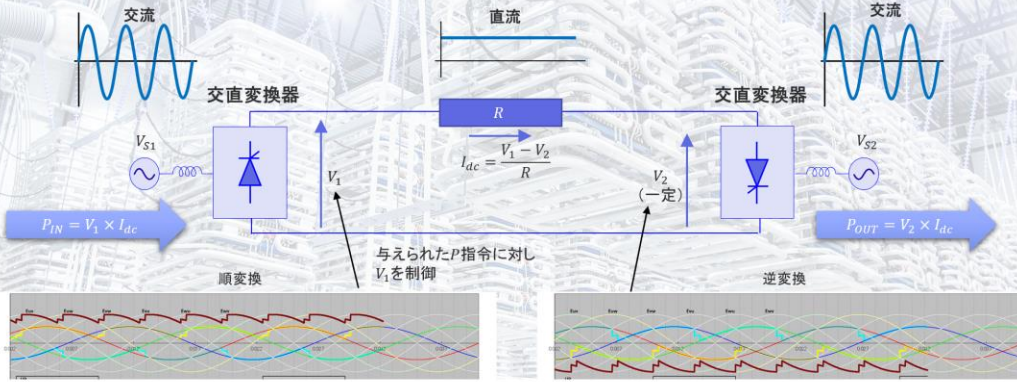

他励式HVDC

他励式HVDCの基本原則 順変換器と逆変換器

順変換 (点弧角=15°)

逆変換 (点弧角=150°)

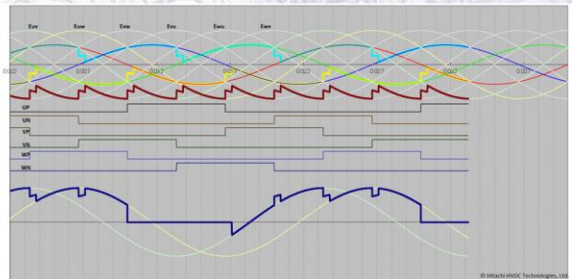
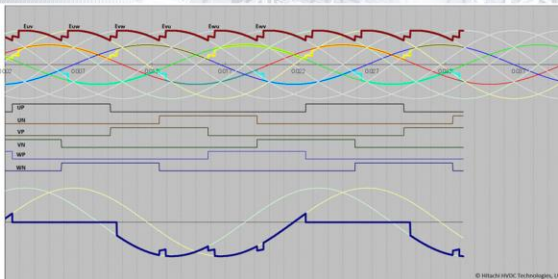

他励式HVDC

HITACHI
 Inspire the Next

他励式HVDCの基本原理(例)

交流電源を整流し直流電圧を作る。両端の直流電圧の差により電流を流し、電力を送る。

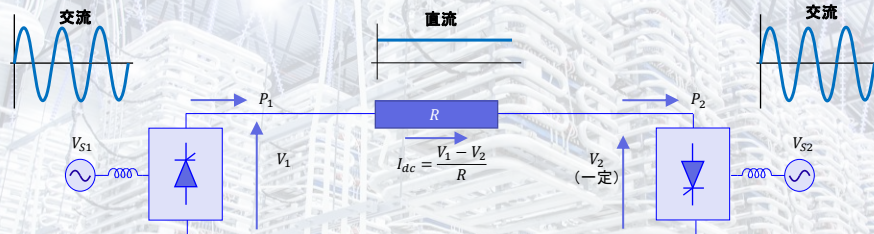

V_1	V_2	R	I_{dc}	P_1	P_2
100	99	1	1	100	99
101	99	1	2	202	198

35

 Public
 © 2023 Hitachi Energy. All rights reserved.

他励式HVDC

HITACHI
 Inspire the Next

他励式HVDCの基本原理(例)

交流電源を整流し直流電圧を作る。両端の直流電圧の差により電流を流し、電力を送る。

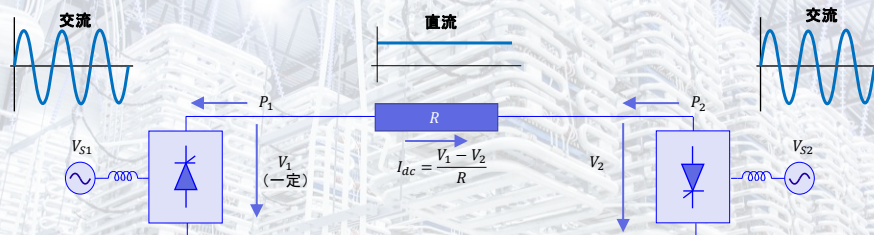

V_1	V_2	R	I_{dc}	P_1	P_2
100	99	1	1	100	99
101	99	1	2	202	198
-99	-100	1	1	-99	-100

36

 Public
 © 2023 Hitachi Energy. All rights reserved.

マルチレベル変換器 (1)

HITACHI
 Inspire the Next

自動式直流送電においては損失が低く、高調波の発生が少ない
 マルチレベル変換器が主流

回路方式	2レベル変換器	マルチレベル変換器
概略図		
コンデンサ	直流線路に集中配置 (直流短絡時に放電する)	各セルに分散配置 (直流短絡時にも放電しない)
アーム電圧概略波形		
アーム電流概略波形		

 37 Public
 © 2023 Hitachi Energy. All rights reserved.

マルチレベル変換器 (2)

HITACHI
 Inspire the Next

- 各セルは、IGBT のスイッチング状態に依存して“零電圧”または“コンデンサ電圧”を出力しそれぞれ2レベル波形の出力となる。

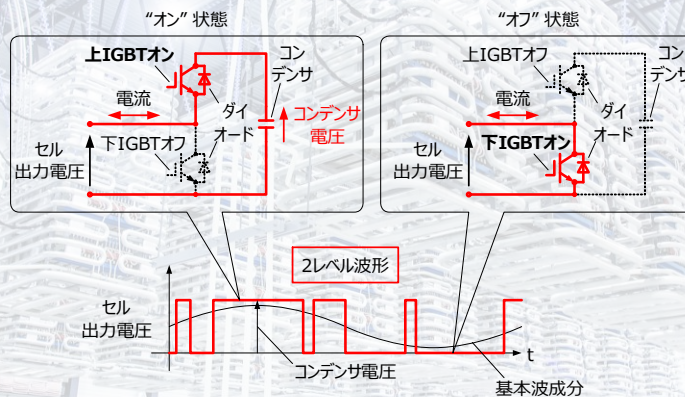

- セル出力電圧は電流の極性(方向)に依らず、IGBT のオン/オフ状態で決定
- セルが“オン”状態の場合、電流はコンデンサを充電/放電

 38 Public
 © 2023 Hitachi Energy. All rights reserved.

マルチレベル変換器 (3)

HITACHI
 Inspire the Next

- アーム = 複数のセルの直列回路: アーム出力電圧はセル出力電圧の和

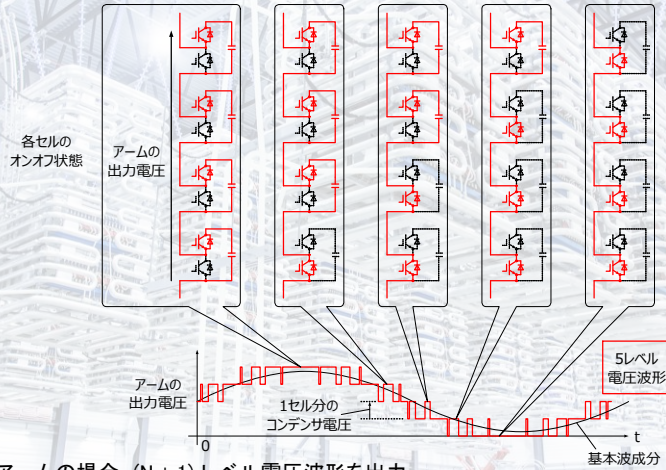

- N セル/アームの場合, (N + 1) レベル電圧波形を出力

 39 Public
 © 2023 Hitachi Energy. All rights reserved.

マルチレベル変換器 (4)

HITACHI
 Inspire the Next

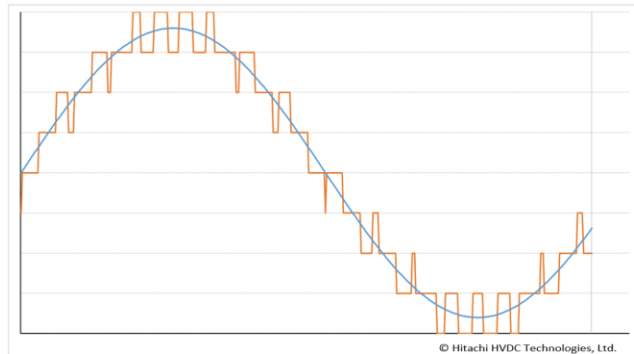
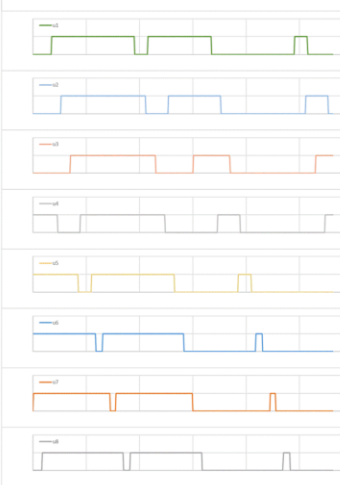
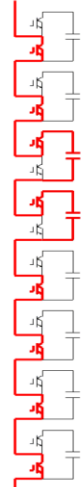
 Number of pulse: 3
 Modulation index: 0.9
 9-Level

© Hitachi HVDC Technologies, Ltd.

※ 実際の HVDC における MMC 制御とは異なります。

 42 Public
 © 2023 Hitachi Energy. All rights reserved.

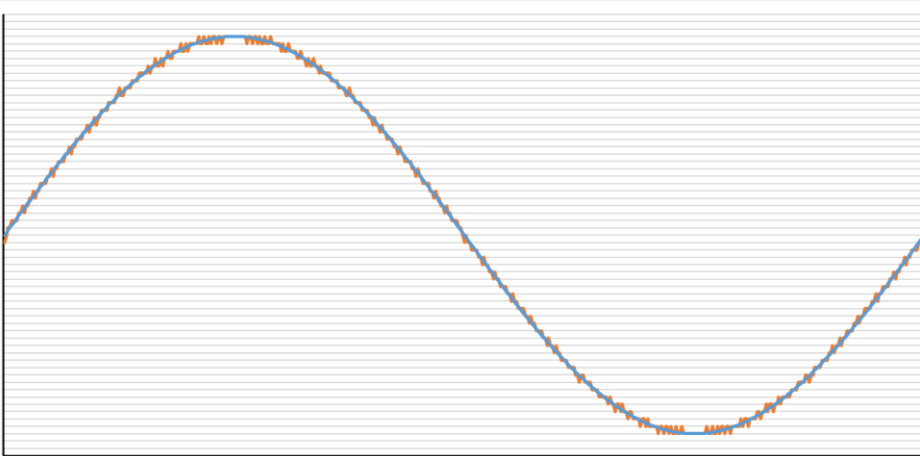
Number of pulse: 3
 Modulation index: 0.9
 61-Level

 41 Public
 © 2023 Hitachi Energy. All rights reserved.

マルチレベル変換器 (5)

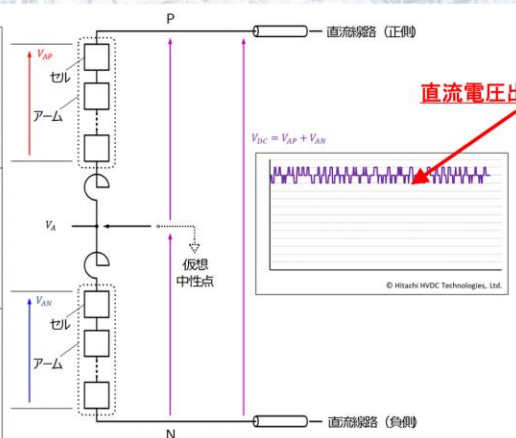
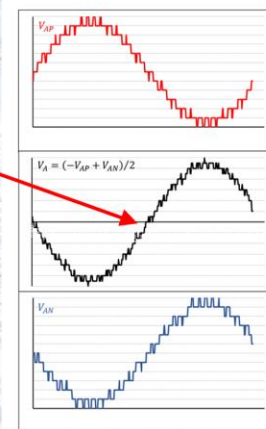
- 正負アームの“差電圧” ⇒ 交流電圧 $V_A = (-V_{AP} + V_{AN})/2$
- 正負アームの“和電圧” ⇒ 直流電圧 $V_{DC} = V_{AP} + V_{AN}$

 交流電圧出力
 振幅と位相を制御

 42 Public
 © 2023 Hitachi Energy. All rights reserved.

自励式HVDCは、系統安定化にも寄与

HITACHI
Inspire the Next

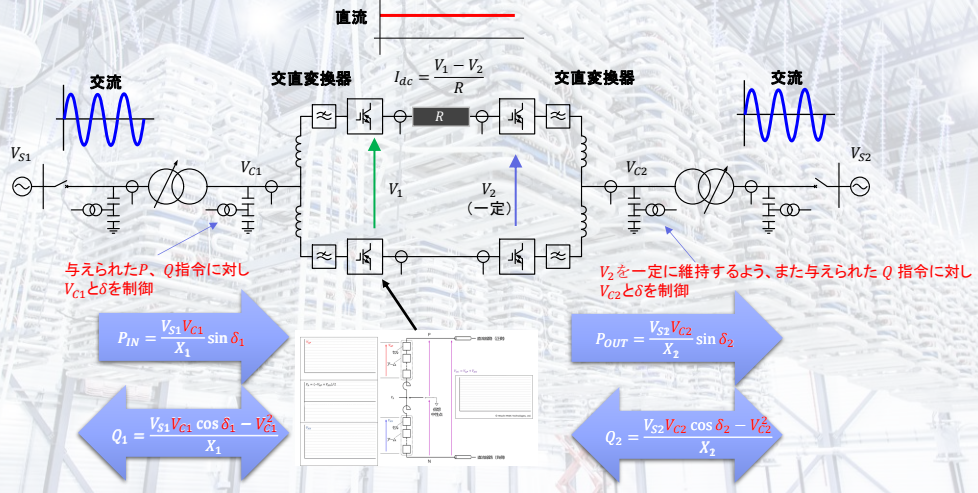
自励式HVDCは、無効電力の供給が可能



43 Public
© 2023 Hitachi Energy. All rights reserved.

Hitachi Energy

自励式／他励式 比較

HITACHI
Inspire the Next

項目	自励式 (VSC)	他励式 (LCC)
転流方式	自己転流	交流電圧を用いて転流
スイッチングデバイス	BIGT、IGBT などの自己消弧素子	サイリスタ(自己消弧できない)
無効電力の供給、制御	変換器により 無効電力の供給 が可能 (系統運用へのベネフィット大)	無効電力を消費するため調相設備が必要となる
有効電力と無効電力の個別制御	変換器にて 有効電力、無効電力の個別制御 が可能 (系統運用へのベネフィット大)	追加設備が必要(基本的には不可)
連系交流系統の制限	連系系統が弱い(短絡容量が小さい)場合でも運転可能 弱い系統では Grid Forming 運転 実施	連系系統は強い(短絡容量が変換器の2~3倍以上)必要がある
ブラックスタート	交流側停電時に ブラックスタート可 (補機電源要)	交流側停電時運転不可(あるいは大規模な対策が必要)
損失(トータル)	変換所あたり約 0.8 %	変換所あたり 0.7 ~ 0.8 % 程度
交流フィルタ、調相設備などの付属設備	不要または小規模	大規模なもの(変換器容量の60%程度)が必要
海底ケーブルの場合	敷設が比較的短期間(XLPE ケーブル)	(XLPE と比較し) ケーブル敷設工期長い
実績	1999 年の商用運転開始以降、約 50 サイトが運開済 (最大容量 5,000 MW (双極) が運開済)	多くの実績(150 サイト以上)があり技術的にも成熟 (最大容量 12,000 MW)
適している用途	ケーブル送電、再エネ連系など、幅広い用途に主流となっていく。	主として、バルクパワーを架空線で長距離送電する場合にニーズがある

LCC: Line Commutated Converter
VSC: Voltage Source Converter

IGBT: Insulated Gate Bipolar Transistor
BIGT: Bi-Mode Insulated Gate Transistor

44 Public
© 2023 Hitachi Energy. All rights reserved.

Hitachi Energy

HITACHI
Inspire the Next

HVDC の系統サポート

45

Public
© 2023 Hitachi Energy. All rights reserved.

Hitachi Energy

HVDC のベネフィット — 系統安定化への寄与 —

HITACHI
Inspire the Next

交流系統における様々な制約

電力系統の定常時における
各種制約

電力系統の安定度
(過渡時等)

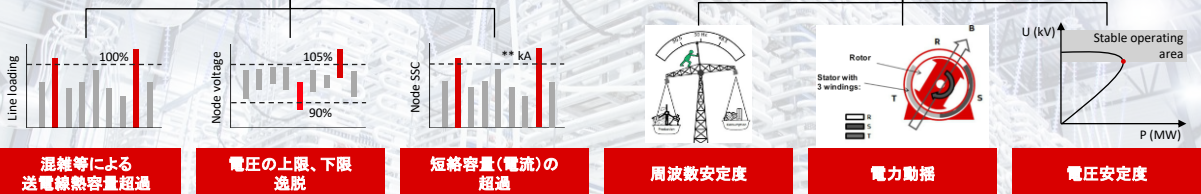

46

Public
© 2023 Hitachi Energy. All rights reserved.

Hitachi Energy

HVDC のベネフィット ー系統安定化への寄与ー



自動式HVDCは、既存交流系統の安定化・効率向上にも寄与

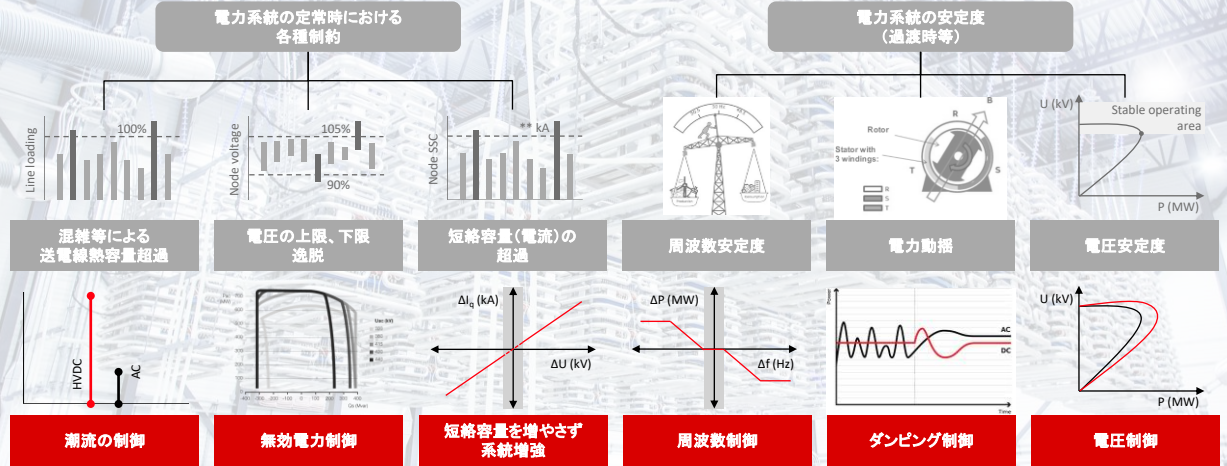

過渡安定度とは



一時的な発電機と原動機のアンバランスにより、発電機が加速/減速し、それに伴い相角度 (rotor angle) が動揺する。相角度が開きすぎると回復不可能となり、発電機が脱調する可能性がある。

Rotor angle stability (transient)

Transient rotor angle change when turbine (P_m) and generator (P_e) power are not balanced; limited by generator inertia

$$\underbrace{\frac{2H}{\omega_0}}_{\text{Rotor inertia}} \cdot \underbrace{\frac{d^2\delta'}{dt^2}}_{\text{Synchronizing power}} = \underbrace{P_m}_{\text{Damping power}} - \underbrace{\frac{U_t E_i}{X'_d} \sin \delta'}_{\text{Synchronizing power}} - \underbrace{P_d}_{\text{Damping power}} \cdot \frac{d\delta'}{dt}$$

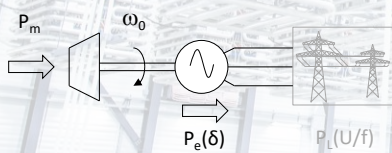

Equal-area criterion:

- A_1 Accelerating Area
- A_2 De-accelerating Area
- δ_{c2} Critical clearing angle
- δ_{c2} must make sure A_2 bigger than A_1 to ensure stability

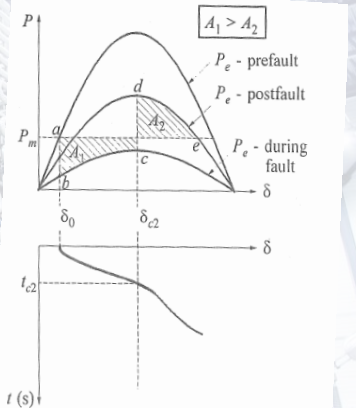

HVDCの高速制御による系統安定化（過渡安定度向上）例

Kundur 2 area test model（標準 2エリアテストモデル）を用いた解析例

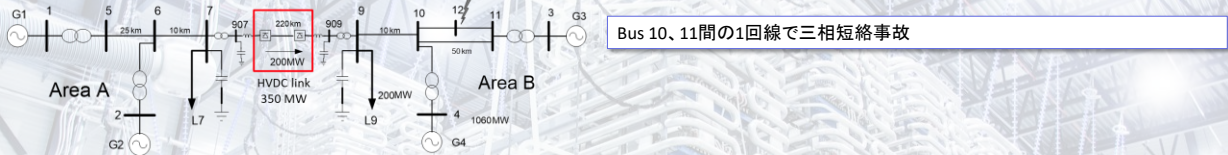

① HVDC出力一定運転 ⇒ 発電機同期はずれ発生

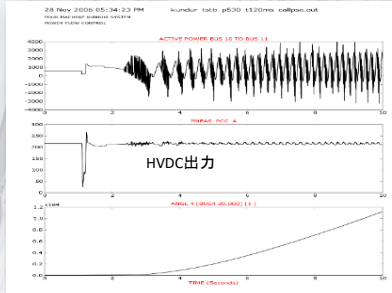

② HVDC出力を高速制御し安定化

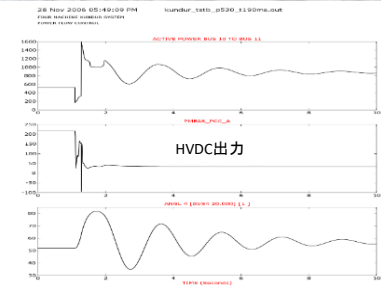

③ さらに過酷な事故に対しても安定化

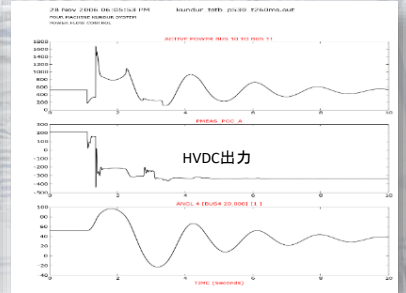

HVDCの高速制御による系統安定化の例（RoCoF 緩和、周波数安定度向上）

Kundur 2 area test model（標準 2エリアテストモデル）を用いた解析例

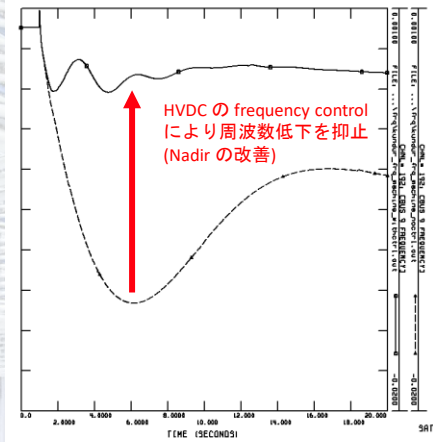
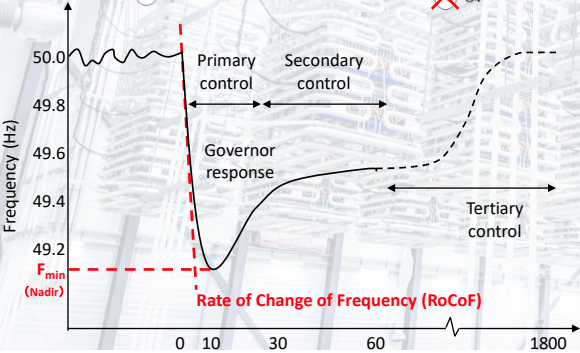

HVDCの高速出力応答による過渡安定度向上（カナダでの解析実例）

HITACHI
Inspire the Next

Maritime Link（カナダ） 双極 500 MW

HVDCの高速出力制御により、ニューファンドランド島系統のレジリエンスを強化（系統故障時の周波数・電圧安定化）

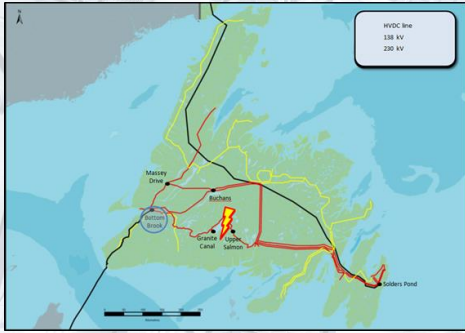

51 Public
© 2023 Hitachi Energy. All rights reserved.

Hitachi Energy

HVDCによる電圧安定度向上（スコットランドでの実系統での例）

HITACHI
Inspire the Next

Caithness Moray（英国スコットランド） 1,200MW / 800MW

急増するスコットランド北部の風力をHVDCにより需要地に送電するとともに、弱い北部系統を安定化

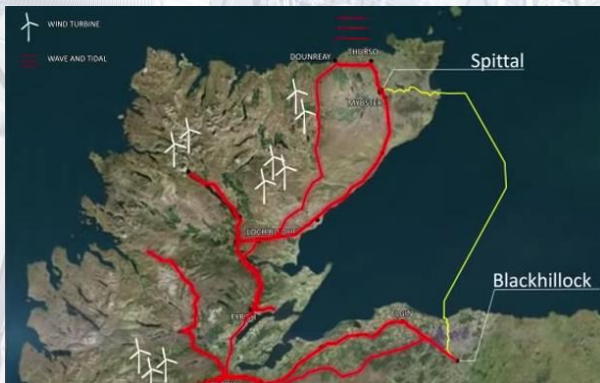

Courtesy: Scottish & Southern Electricity Networks

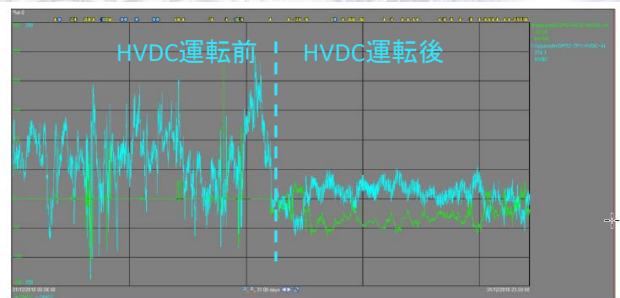

HVDC運転開始月の Spittal の電圧波形

52 Public
© 2023 Hitachi Energy. All rights reserved.

Hitachi Energy

DC Links in AC Grids (同期系統内に既存交流系統と並行に設置されるHVDC)

DC Links in AC Grids の効果

- (トータル)送電損失の低減
- 交流送電線の過負荷防止
- 交流系統の TTC* 拡大(安定度向上により安定度限界によるTTC 制約を緩和)
- 長周期動揺のダンピング、ループフローの制御等
- 系統のレジリエンス向上
- トータル送電コストの最適化

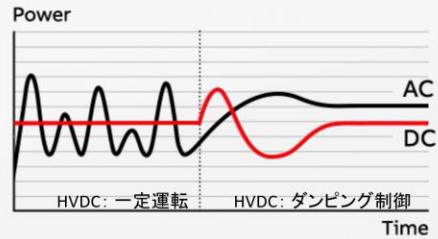
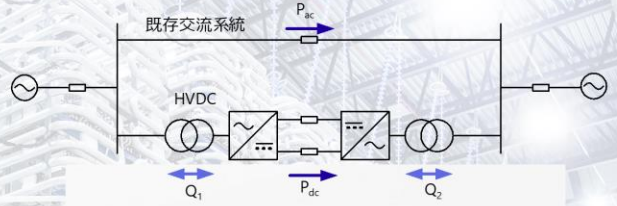

各地で同期系統内(既存交流系統と並行して)に設置されるHVDCが増加中(図の他にも実績多数)



* TTC: Total Transfer Capability、その時点での送電可能容量(系統の安定度等により影響を受ける)

弱い系統をサポートする HVDC 制御スキーム

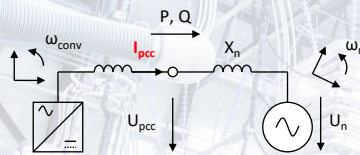

通常の系統

- $ESCR^* > 1.5$
- 変換器は系統電圧に同期して制御(Grid following)
- 系統への電流を制御することにより P, Q を制御
- 系統位相に対して PLL を使って高速に同期 (fast synchronization)

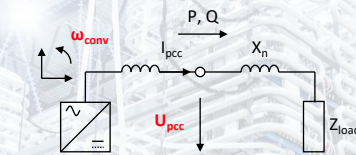

単独系統制御(Islanded operation)

- 同期する系統電圧がない。ESCR = 0 (ブラックスタート系統、洋上風力ネットワーク等の単独系統)
- 変換器は電圧と周波数を制御
- P, Q は制御せず、系統の負荷により決められる(風車の発電した電力がそのままHVDCに送られる)

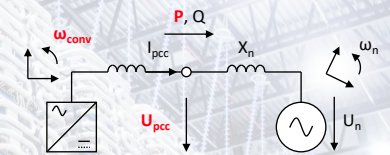

非常に弱い系統

- $ESCR < 1.5$
- 変換器出力電流 I_{pcc} が系統の電圧位相に影響する
- P 制御は電圧位相制御による(Grid forming)
- 系統の電圧位相にゆるやかに同期 (slow synchronization)

* ESCR: Effective Short Circuit Ratio、有効短絡容量比
* PLL: Phase Locked Loop、位相同期回路

弱いシステムをサポートする HVDC 制御スキーム

HITACHI
Inspire the Next

Grid Forming 運転中の系統事故に対しても安定して運転を継続

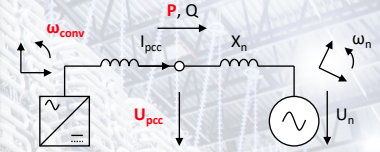
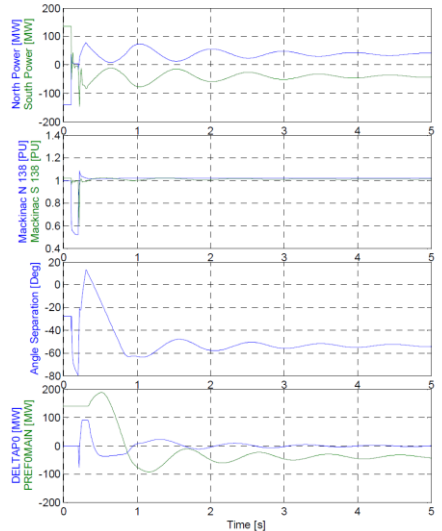

非常に弱い系統

- $ESCR < 1.5$
- 変換器出力電流 I_{pcc} が系統の電圧位相に影響する
- P 制御は電圧位相制御による (Grid forming)
- 系統の電圧位相にゆるやかに同期 (slow synchronization)

55 Public
© 2023 Hitachi Energy. All rights reserved.

Hitachi Energy

HITACHI
Inspire the Next

システム解析

56 Public
© 2023 Hitachi Energy. All rights reserved.

Hitachi Energy

シミュレーション解析による検証

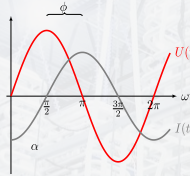
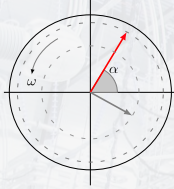
HITACHI
Inspire the Next

種別	RMS test (実効値解析)	EMT test (瞬時値解析)	Factory test (工場試験)	Site test
用途	上位制御系の設計検証 安定性解析	下位制御系の検証 過渡解析	実機の制御システムの動作検証	試運転 (系統連系試験)
系統モデル	広域系統モデル	縮約系統モデル (近傍系統を詳細模擬)	等価モデル (短絡容量模擬など)	実系統
計算時間	短	長	リアルタイム	— (実系統)
解析対象	$f < 50 \text{ Hz}, t = 3 \sim 30 \text{ s}$	$f > 50 \text{ Hz}, t = 0.001 \sim 3 \text{ s}$	$t = 0.01 \sim \infty \text{ s}$	$0 < f < \infty, t = 0.001 \sim \infty \text{ s}$

 57 Public
© 2023 Hitachi Energy. All rights reserved.

解析 (オフライン) と FST (Factory System Test)

HITACHI
Inspire the Next

Software in-the-loop (Virtual MACH)

非リアルタイムシミュレーション (オフライン)

実際の制御ロジック Actual control logic
 実際のソースコード Actual source code
 ハードウェアおよび主回路モデル Emulated hardware

標準PC + カスタマイズされたソフトウェア
 シミュレーションツール
 ACおよびDCの回路模擬にほぼ制限がない
 スケーリングが容易

Accuracy/scale dictates simulation speed

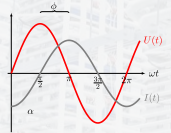

Hardware in-the-loop (MACH)

リアルタイムシミュレーション (オンライン)

実際の制御ロジック Actual control logic
 実際のソースコード Actual source code
 実際の制御保護ハードウェア + 主回路モデル Actual hardware

最新技術かつカスタマイズされたハードウェア
 リアルタイムシミュレータ
 縮約されたACおよびDCの回路模擬
 スケーリングは難しく、時間を要する

Simulation speed dictates accuracy/scale



正確なオフラインシミュレーションにより、効率的な制御設計が可能

 58 Public
© 2023 Hitachi Energy. All rights reserved.

システム解析による検証精度

HITACHI
Inspire the Next

J. HERNANDEZ, K. KRANDER, S. AYOUB, A. A. MITSCH, M. MENSINGET

Hitachi Energy Sweden, Bonneville Power Administration USA, Statnett Norway

Summary: The integration of renewable energy systems has increased the demands on converter control and protection (C&P) systems to comply with specifications and grid codes, and to handle interconnection concerns. This poses a challenge in terms of designing and testing the robustness and performance of a C&P system in a wide range of operating conditions and contingencies. As a result, the C&P system is often designed and tested under multiple static and transient operating conditions in an emulated environment, several case studies and real-time testing before the final commissioning.

Offline simulations are built up widely with software utilizing digital models and tools, also known as software-in-the-loop (SIL). Other operations like the use of hardware-in-the-loop (HIL) and real-time simulation, also known as hardware-in-the-loop (HIL), bring offline and online simulation to the key to ensuring quality and decreasing lead-time for efficient commissioning of the C&P system. Still, it remains a challenge to ensure that the simulation platform is able to cover all the required operating conditions and contingencies. This paper discusses the potential of the proposed framework to perform the commissioning of C&P systems in the offline domain, highlighting the key features which enable an accurate representation of a real C&P system, and address the main challenges and difficulties when performing this type of commissioning, through a case study.

Keywords: LCC, VSC, HVDC, FACTS, off-line EMT simulation, control and protection, and site experience.

4.2 VSC HVDC - NordLink

Since 2020, the NordLink interconnector has linked power grids in Norway and Germany to enable the integration and exchange of renewable wind and solar power between these two countries. The challenge arises in terms of the Norwegian water, biomass, and the Western system is covered by the German utility TenneT. The link has a transmission capacity of 1,400 MW at 525 kV DC.

During the commissioning, a complex grid setup had to be modeled to verify the performance of the DC overhead line protection. After the fault, pole 1 continued operation and the power order was set into a single line diagram as shown in Figure 5. Comparison plots for pole 1 and pole 2 are shown in Figure 7a and 7b, respectively.

In section 4.1, some of the challenges that occur performing commissioning on HVDC bipolar configurations were mentioned. To this can be added that special care must be taken when performing commissioning as a converter that operating at extended low power values in relation to its nominal power. On the main circuit side, attention must be paid to accurate modeling of the grounding system and measurement equipment which lead to measurement on measured voltage and current. The transient of the secondary side of a capacitive voltage transformer (CVT) can be clearly seen in Figure 7b (CVT voltage offset 1).

As seen in the plots, the offline EMT simulation results nearly match site measurements for the corresponding signals from the healthy pole and fault pole. It must also be recognized that the natural frequency of a VSC system are much faster than an LCC system, which gives concern over the actual simulation.

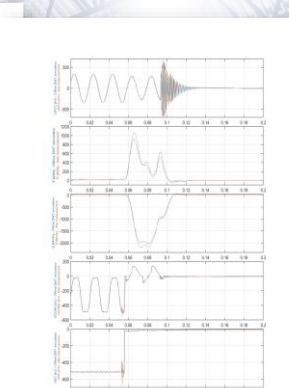
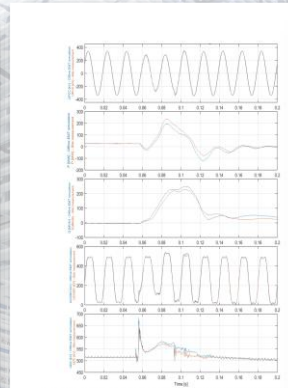
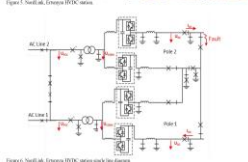

Figure 5: NordLink, Off-line EMT simulation. Single line diagram for healthy pole (Pole 1) and fault pole (Pole 2).
Figure 6: NordLink, Off-line EMT simulation. Single line diagram for healthy pole (Pole 1) and fault pole (Pole 2).
Figure 7a: NordLink, Off-line EMT simulation. Single line diagram for healthy pole (Pole 1) and fault pole (Pole 2).
Figure 7b: NordLink, Off-line EMT simulation. Single line diagram for healthy pole (Pole 1) and fault pole (Pole 2).
Figure 7c: NordLink, Off-line EMT simulation. Single line diagram for healthy pole (Pole 1) and fault pole (Pole 2).

Cigre C4 10819 "Virtual C&P - A powerful simulation platform for HVDC and FACTS in present and future grids"

Hitachi Energy

システム解析による検証精度

HITACHI
Inspire the Next

J. HERNANDEZ, K. KRANDER, S. AYOUB, A. A. MITSCH, M. MENSINGET

Hitachi Energy Sweden

Summary: The integration of renewable energy systems has increased the demands on converter control and protection (C&P) systems to comply with specifications and grid codes, and to handle interconnection concerns. This poses a challenge in terms of designing and testing the robustness and performance of a C&P system in a wide range of operating conditions and contingencies. As a result, the C&P system is often designed and tested under multiple static and transient operating conditions in an emulated environment, several case studies and real-time testing before the final commissioning.

Offline simulations are built up widely with software utilizing digital models and tools, also known as software-in-the-loop (SIL). Other operations like the use of hardware-in-the-loop (HIL) and real-time simulation, also known as hardware-in-the-loop (HIL), bring offline and online simulation to the key to ensuring quality and decreasing lead-time for efficient commissioning of the C&P system. Still, it remains a challenge to ensure that the simulation platform is able to cover all the required operating conditions and contingencies. This paper discusses the potential of the proposed framework to perform the commissioning of C&P systems in the offline domain, highlighting the key features which enable an accurate representation of a real C&P system, and address the main challenges and difficulties when performing this type of commissioning, through a case study.

Keywords: LCC, VSC, HVDC.

健全極の交流電圧、P、Q

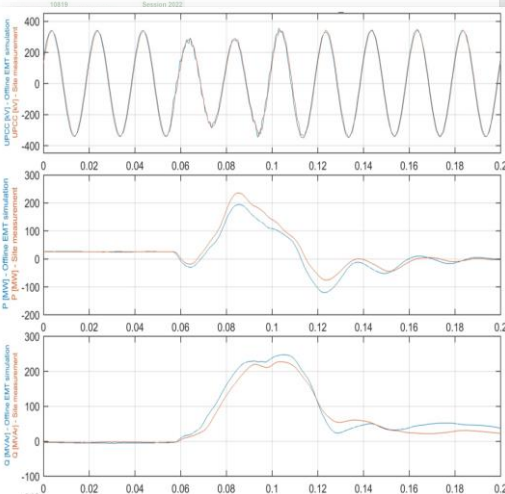

事故極の交流電圧、P、Q

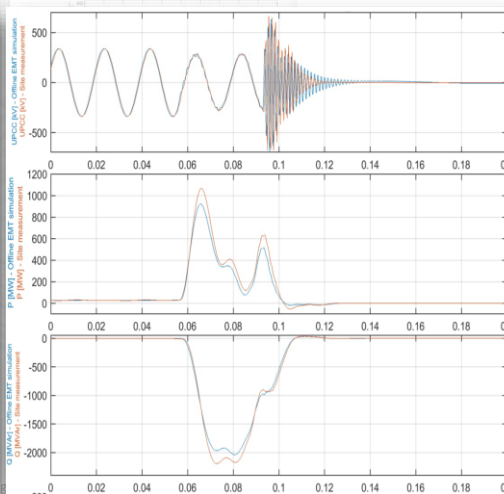

Cigre C4 10819

Hitachi Energy

HITACHI
Inspire the Next

プロジェクト事例

61 Public
© 2023 Hitachi Energy. All rights reserved.

 **Hitachi Energy**

プロジェクトの例

HITACHI
Inspire the Next

Mackinac BtB (2014, US)
200 MW



Skagerrak 4 (2014, Norway – Denmark)
700 MW



DolWin 2 (2017, Germany)
900 MW



Maritime Link (2018, Canada)
500 MW



Caithness – Moray – Shetland (2018, 2024,
UK) 1,200 – 800 – 600 MW



IFA2 (2021, UK – France)
1,000 MW



NordLink (2020, Germany – Norway)
1,400 MW



North Sea Link (2021, Norway – UK)
1,400 MW



Dogger Bank A, B and C (2023-26, UK)
3 × 1,200 MW



DolWin 5 (2024, Germany)
900 MW



Lightning (2025, Abu Dhabi)
3,200 MW



東清水 (2028, 日本)
2 × 300 MW









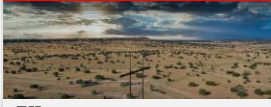

62 Public
© 2023 Hitachi Energy. All rights reserved.

 **Hitachi Energy**

最近の代表的受注案件

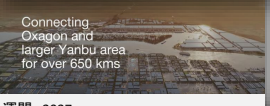
HITACHI
Inspire the Next

<p>SunZia (米)</p>  <p>運開: 2026 用途: 陸上風力連系 容量: 3,000 MW (±525 kV)</p>	<p>TenneT offshore (独・蘭)</p>  <p>運開: 2028-31 用途: 洋上風力連系 容量: 6 x 2,000 MW (±525 kV) Total 12,000 MW</p>	<p>SuedLink DC4 (独)</p>  <p>運開: 2029 用途: 南北のグリッド接続 (風力-需要地) 容量: 2,000 MW (±525 kV)</p>	<p>Saudi Arabia – Egypt</p>  <p>運開: 2025 用途: 国際連系 容量: 3,000 MW (±500 kV multi-terminal)</p>
<p>Champlain Hudson (米・加)</p>  <p>運開: 2025 用途: 非同期系統連系 容量: 1,250 MW (±400 kV)</p>	<p>Hornsea 3 (英)</p>  <p>運開: 2027 用途: 洋上風力連系 容量: 2 x 1,320 MW (±320 kV) Total 2,640 MW</p>	<p>ENOWA (サウジ)</p>  <p>Connecting Okazaki and larger Yanbu area for over 650 kms</p> <p>運開: 2027 用途: スマートシティへの送電 容量: 3 x 3,000 MW (±525 kV) Total 9,000 MW</p>	<p>Project Lightning (UAE)</p>  <p>運開: 2025 用途: 洋上への送電 容量: 2 x 1,000 MW (±320 kV) 1,200 MW (±400 kV) Total 3,200 MW</p>

長距離地域間連系の例 North Sea Link

HITACHI
Inspire the Next

<p>Customer Statnett SF in Norway and National Grid in United Kingdom</p>		
<p>Customer needs</p> <ul style="list-style-type: none"> Security of supply Meet EU's target for CO₂ reduction Energy trade 		
<p>Our response</p> <ul style="list-style-type: none"> Two 1,400 MW, ±515 kV HVDC Light® converter stations 		
<p>Customer benefits</p> <ul style="list-style-type: none"> Security of supply Fluctuations in power demand to be met by using the other country's renewable surplus power 		
<p>Year 2021</p>		
<p>HVDC Light® converter stations</p>	<ul style="list-style-type: none"> Bipolar ±515 kVdc Kvittdal: 420 kV Blyth: 400 kV 	<p>Land and sea DC cable system</p>

Increased security of power supply and social-economic benefits for both countries

長距離地域間連系の例 North Sea Link

HITACHI
 Inspire the Next

North Sea Link: 2021年運開、自励式 ± 515 kV, 1400 MW (双極)

UK



Norway

 65 Public
 © 2023 Hitachi Energy. All rights reserved.

国・地域間連系の日立実績 (自励式 HVDC)

HITACHI
 Inspire the Next

Project	Country・area	Year	Size (MW)
East-West Interconnector	Ireland-UK	2013	500
Mackinac	USA	2014	200 (BTB)
Skagerrak 4	Norway-Denmark	2014	700
Kriegers-Flak CGS (Multi-purpose interconnection)	Germany - Denmark	2020	410 (BTB)
NordBalt	Sweden-Lithuania	2017	700
Maritime Link	Canada	2018	500
Caithness-Moray-Shetland (Multi-terminal)	Scotland, UK	2018/24	600-800-1,200
IFA2	UK-France	2021	1,000
NordLink	Germany-Norway	2020	1,400
North Sea Link	Norway-UK	2021	1,400
Champlain Hudson Power Express	USA-Canada	2026	1,250
Châteauguay BTB	USA-Canada	2026	1,500
Biscay Gulf Link	France-Spain	2027	2,200
Yanbu	Saudi Arabia	2027	3,000
東清水	日本	2028	2 x 300
SuedLink DC4	Germany	2029	2,000
Eastern Green Link 2	UK	2029	2,000
Spittal-Peterhead	Scotland, UK	2030	2,000
Western Isles	Scotland, UK	2030	2,000

 Public
 © 2023 Hitachi Energy. All rights reserved.

Energy transition が世界中で加速

HITACHI
Inspire the Next

2023/01/18 Hitachi Energy signs agreements with ENOWA and Saudi Electricity Company to design and develop the first phase of visionary NEOM region transmission system
Hitachi Energy
< News
Press Release | 30-05-2023 | 5 min read

Hitachi Energy signs agreements with ENOWA and Saudi Electricity Company to design and develop the first phase of visionary NEOM region transmission system



Hitachi Energy signs agreement with ENOWA, and Saudi Electricity Company to provide three HVDC links for a total power capacity of 9 gigawatts in Western Saudi Arabia. Seated from left are: Muth Al-Suhabani, General Manager SEPCO, Ahmed Al-Zahrani, Acting CEO National Grid SA, SEC, Niklas Persson, Managing Director of Hitachi Energy's Grid Integration business, and Thorsten Schwarz, Executive Director, Grid Technologies & Projects, Energy of ENOWA.

このページをシェアする

Collaboration to accelerate the development of NEOM in Saudi Arabia with up to 9 gigawatts of power transmission capacity

Hitachi Energy, a global technology leader advancing a sustainable energy future for all, has signed agreements under the supervision and management of the Ministry of Energy with the Saudi Electricity Company (SEC) and with ENOWA. The agreements include the supply of three high-voltage direct current (HVDC) transmission systems to end customer ENOWA, the utility company for NEOM in Northwest Saudi Arabia. Built with sustainability in mind, NEOM is among Saudi Arabia's Giga-Projects.

https://www.hitachienergy.com/japanese/en/news/2023/05/hitachi-energy-signs-agreements-with-enowa-and-saudi-electricity-company-to-18
Public
© 2023 Hitachi Energy. All rights reserved.

67



最初のプロジェクト Yanbu (± 525 kV / 3,000 MW) は、プロジェクト期間 48 カ月

CONFIDENTIAL

洋上風力連系の例

HITACHI
Inspire the Next

Dogger Bank A, B & C (英国) 1,200 MW x 3 (合計 3,600 MW)

Customer	SSE Renewables (英国)、Equinor (ノルウェー)
Customer needs	<ul style="list-style-type: none"> 200 km のケーブル送電 ロバストでレジリエントなグリッド接続
Key features	<ul style="list-style-type: none"> 1,200 MW、±320 kV、HVDC Light® system x 3
Customer benefits	<ul style="list-style-type: none"> 環境に適合し安全な系統接続 低損失と高信頼度 消費者にクリーンな電力を届ける 英国のCO2排出の低減
運用開始	<ul style="list-style-type: none"> Dogger Bank A: 2023年 Dogger Bank B: 2024年 Dogger Bank C: 2026年

Illustrated image of offshore wind connection by Abel
CONFIDENTIAL

68

Public
© 2023 Hitachi Energy. All rights reserved.

風力連系（陸上、洋上）の日立実績



Project	Country*area	Year	Size (MW)
BorWin1	Germany	2015	400
Dolwin1	Germany	2015	800
DolWin2	Germany	2017	916
Kriegers-Flak CGS	Germany - Denmark	2020	410 (BtB)
Dogger Bank A	UK	2023	1,200
Dogger Bank B	UK	2024	1,200
DolWin 5	Germany	2024	900
SunZia	US	2026	3,000
Dogger Bank C	UK	2026	1,200
Hornsea 3	UK	2027	2,850
Lanwin 5	Germany	2028 - 31	2,000
Doordewind 1	Netherlands	2028 - 31	2,000
Doordewind 2	Netherlands	2028 - 31	2,000
Nederwiek 1	Netherlands	2028 - 31	2,000
Nederwiek 3	Netherlands	2028 - 31	2,000
Ijmuiden Ver Alpha	Netherlands	2028 - 31	2,000



abel

69 Public © 2023 Hitachi Energy. All rights reserved.



Dogger Bank が送電を開始（受注から 38 か月）

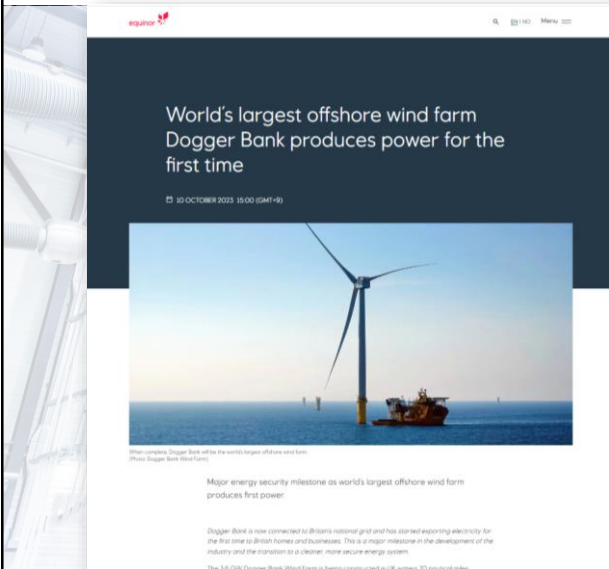

本稿は、スライフォードにおいて、10月10日 8:30(日本時間 15:30)に発表しました。

HITACHI Inspire the Next

2023年10月11日
日立エナジー

日立エナジーが HVDC 変換所を提供した 世界最大のドッガーバンク洋上風力発電所が初送電を達成

日立エナジーが HVDC 変換所を提供した世界最大の洋上風力発電所ドッガーバンク風力発電所に於いて、ドッガーバンクの初送電と英国本土への初送電が実現され、当社が HVDC システムの動作試験や性能検証に関する支援を行いました。今回の初送電は、世界的な新記録となり、この成功は多大な中にも、高い安全性と品質を確保しながら、18 か月という短期間で実現されました。

英国本土から約 130km 北東に位置するドッガーバンク風力発電所は、ドッガーバンク A、B、C の 3 の風力発電所を構成しており、日立エナジーは 2019 年、ドッガーバンク A を最初に洋上 HVDC 変換所 2 基（洋上 HVDC 変換所 2 基）と 4 基（陸上 HVDC 変換所 2 基）を 2021 年に、ドッガーバンク C 向けに洋上・洋上 HVDC 変換所 2 基を受注しました。

ドッガーバンク風力発電所は、英国エネルギー大手 SSE plc グループ傘下の再生可能エネルギー事業者である SSE リニューアブルズと、バルターのエネルギー事業会社リノール、同じくバルターの洋上風力発電事業者アムールとの合弁による世界最大の洋上風力発電所です。2016 年の完成後、英国の電力需要の約 1%、400 万世帯に相当する 3,600 MW の電力を供給することが可能です。これは、2030 年までに電力需要の最大 3 分の 1 を洋上風力発電で満たすという英国政府の目標達成に大きく貢献する

1 / 4

70 Public © 2023 Hitachi Energy. All rights reserved.



近年の自励式 HVDC の 典型的な容量、電圧

HITACHI
 Inspire the Next

対称単極

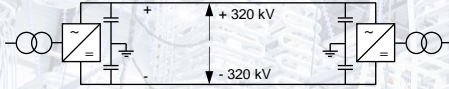
 DC voltage
 $\pm 320 \text{ kV}$

 Power
 800 ~ 1,800 MW

双極 (導體帰還)

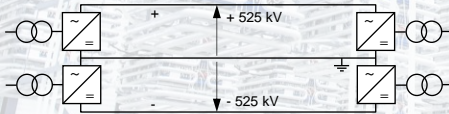
 DC voltage
 $\pm 525 \text{ kV}$

 Power
 2,000 ~ 3,000 MW

71

 Public
 © 2023 Hitachi Energy. All rights reserved.

近年の自励式 HVDC の 典型的なレイアウトと容量

HITACHI
 Inspire the Next

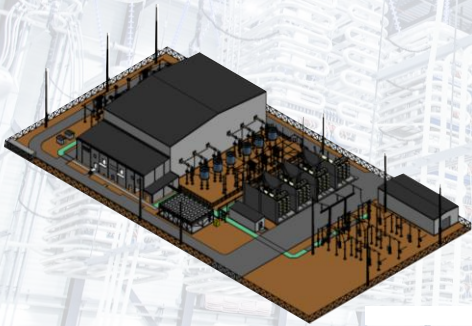
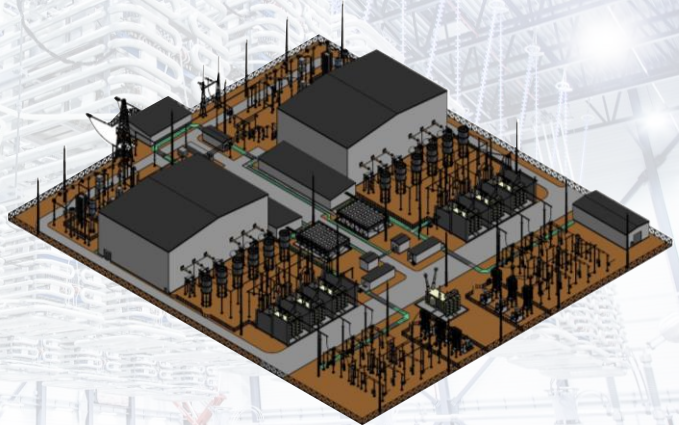
 対称単極 ($\pm 320 \text{ kV}$)
 900 – 1,900 MW

 双極 ($\pm 525 \text{ kV}$)
 2,000 – 3,000 MW

72

 Public
 © 2023 Hitachi Energy. All rights reserved.

洋上風力連系 HVDC 外観

HITACHI
Inspire the Next

対称単極 (±320 kV) のHVDC変換所 (例)
(900 ~ 1,300 MW)



Lean design platform.
Source: Albel

Dogger Bank A&B onshore station



<https://doggerbank.com/construction/onshore/>

双極 (±525 kV) のHVDC変換所 (例)
(2,000 MW)



with a new 2 gigawatt standard offshore grid connection.

Standard design platform.
Source: TenneT



<https://electra.cigre.org/321-april-2022/technology-e2e/next-generation-offshore-grid-connection-systems-tennets-2-gw-standard.html>

CONFIDENTIAL

日立のHVDC事業

HITACHI
Inspire the Next

Hitachi Energy Ludvika

HITACHI
Inspire the Next

- スウェーデン Ludvika (ストックホルムから北西に約 200 km)
- 従業員約 4,000 人、120 年の歴史
- HVDC、変圧器、高電圧機器の開発・設計・製造
- 世界有数の研究所と大型高電圧試験設備を保有
- 2023 年 8 月現在、40 GW 超の新設 VSC HVDC プロジェクトが進行中



Uno Lamm HVDC Center, Hitachi Energy Ludvika



Hitachi Energy Ludvika - A world center of high voltage -

HITACHI
Inspire the Next

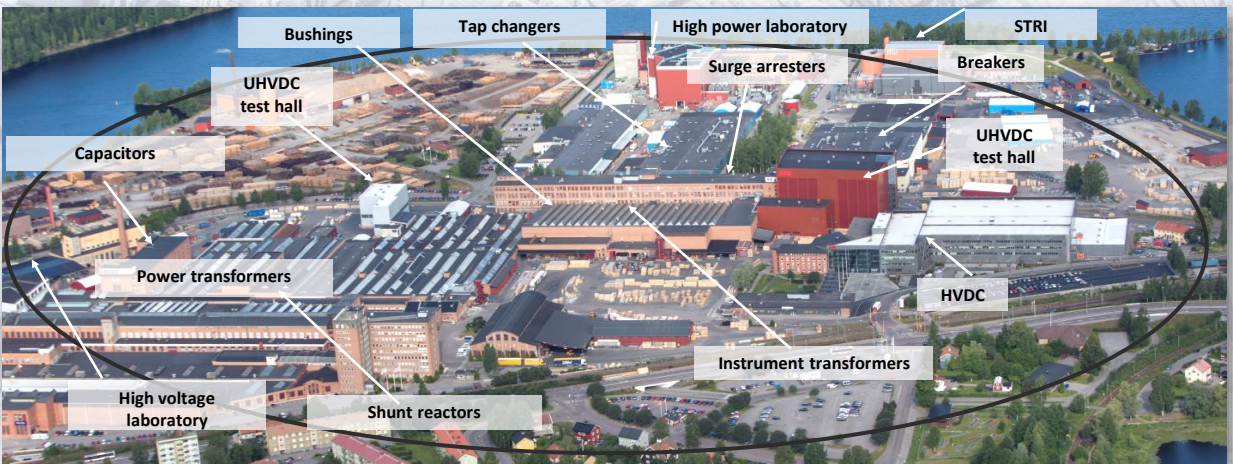

To meet the market demand

HITACHI
Inspire the Next

- 2020年 スウェーデン Ludvika の HVDC 生産設備を拡張
- 2022年8月 スウェーデン Smedjebacken に HVDC 生産工場を新設
- 2023年2月 インド チェンナイに HVDC 生産工場を新設
- 2023年11月 2024年に、スウェーデン Ludvika および Smedjebacken の HVDC 生産設備を拡張することを発表

市場の要求に応えるため、継続的な設備増強、人員増強を実施中

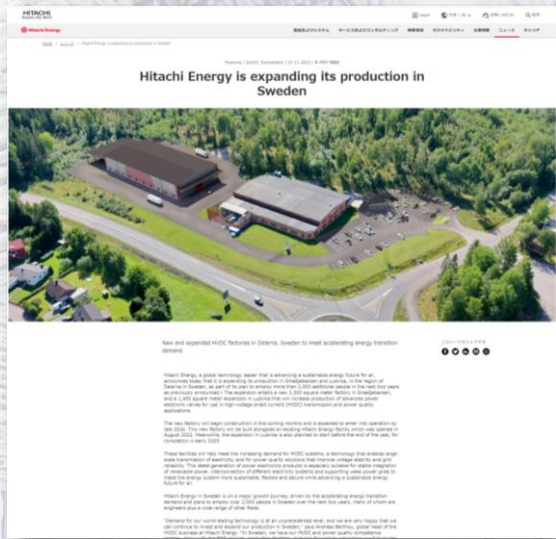

<https://www.hitachienergy.com/se/sv/news/features/2023/11/hitachi-energy-is-expanding-its-production-in-sweden>

Hitachi Energy

77 Public
© 2023 Hitachi Energy. All rights reserved.

2つのワールドクラス高電圧試験設備、その他テストホールを複数保有

HITACHI
Inspire the Next

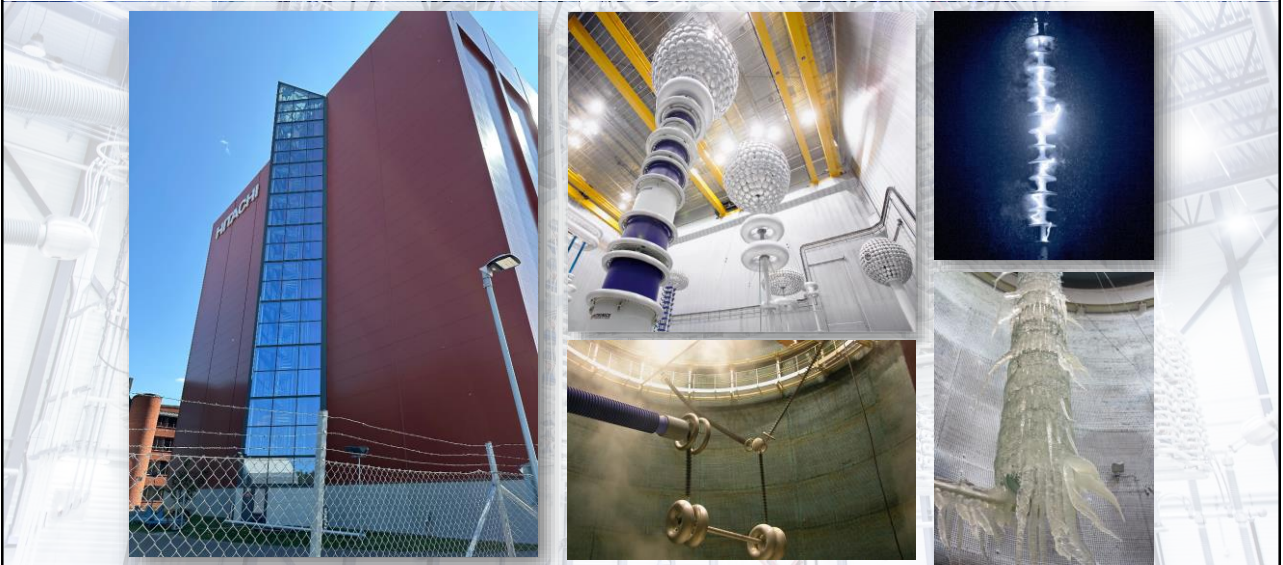

78 Public
© 2023 Hitachi Energy. All rights reserved.

Hitachi Energy

Ludvika 工場 – Photo gallery –

HITACHI
Inspire the Next



79 Public
© 2023 Hitachi Energy. All rights reserved.

Hitachi Energy

HVDC 70 年の歴史をリード

HITACHI
Inspire the Next



80 Public
© 2023 Hitachi Energy. All rights reserved.

Hitachi Energy

日立エナジーが国内 HVDC プロジェクトに提供できること

HITACHI
Inspire the Next

- 多くの実績があり世界各地で運用されている Proven な技術とプロジェクトの知見
- 安心でロバストなシステム
- プロジェクトリスクの低減、工期短縮
- 実績・経験に基づく迅速な情報提供、お客様の計画サポート
- デジタル技術によるプロジェクト遂行の効率化および O&M の高度化



HVDC Light® NordLink (1,400 MW / ±525 kV)

⇒ **カーボンニュートラルへの貢献**

81

Public
© 2023 Hitachi Energy. All rights reserved.

Hitachi Energy



ご清聴ありがとうございました。

お問い合わせ：
西岡 淳
Country M/S Manager, HVDC Japan, PGGI Hitachi Energy
atsushi.nishioka@hitachienergy.com
080-7010-6842

82

Hitachi Energy



HITACHI
Inspire the Next